



# *Spare part's book*

**125**  
SERIES

POWER

1.25 | 2.0 | 2.5 | 2.9

**SHERCO**  
Motorcycles

## Index / Index / Índice

**1** Cadre / Frame / Chasis

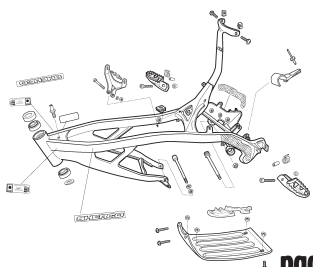

pag. 1 - 4

**2** Plastiques / Plastics / Plásticos

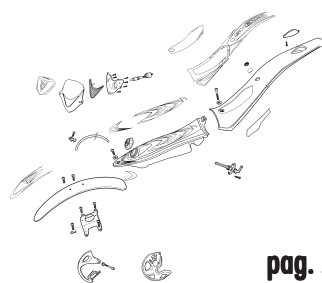

pag. 5 - 8

**3** Guidon / Handlebar / Manillar

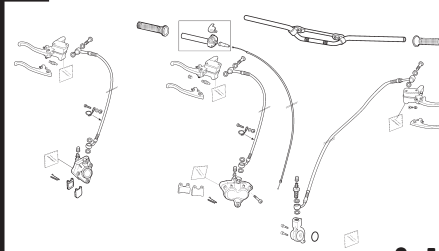

pag. 9 - 12

**4** Radiateur / Radiator / Radiador

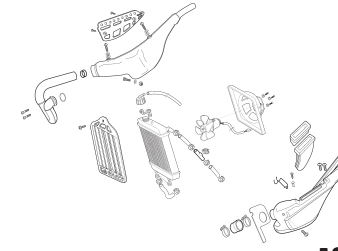

pag. 13 - 16

**5** Bras oscillant / Swingarm / Basculante

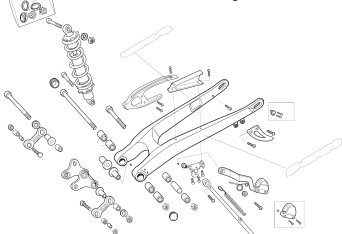

pag. 17 - 20

**6** Roue avant / Front wheel / Rueda delantera

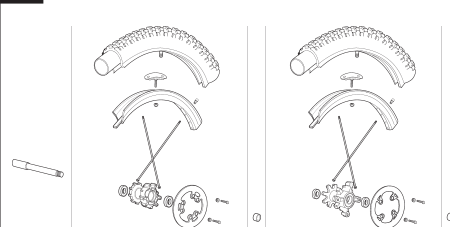

pag. 21 - 22

**7** Roue arriere / Rear wheel / Rueda trasera

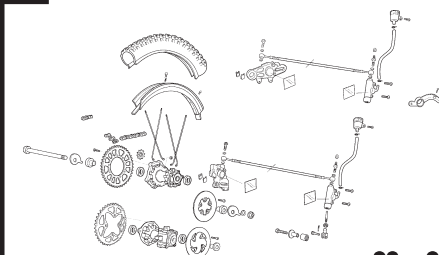

pag. 23 - 26

**8** Fourche / Fork / Horquilla

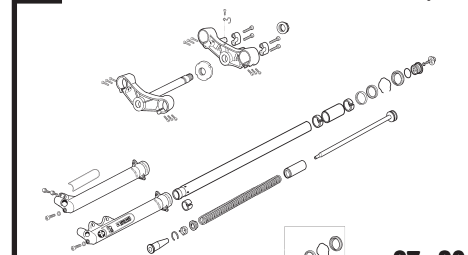

pag. 27 - 30

**9** Kit homologation / Kit homologation / Kit homologación

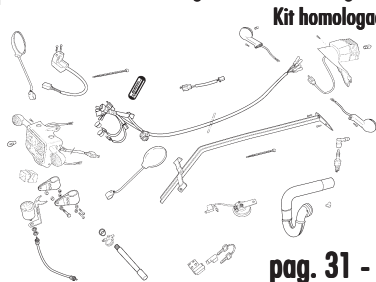

pag. 31 - 34

**10** Moteur / Engine / Motor

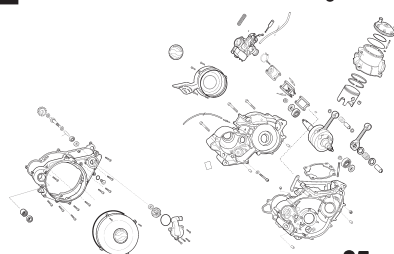

pag. 35 - 40

**11** Boite auitesses / Gear box / Caja de cambios

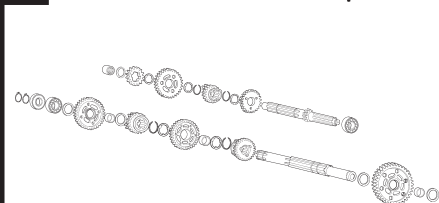

pag. 41 - 44

**12** Embrayage / Clutch / Embrague

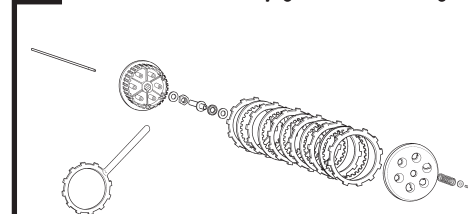

pag. 45 - 46

## Index / Index / Índice

**13** Selection / Selector / Selector

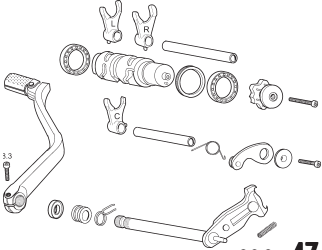

pag. 47 - 48

**14** Demarreur / Kickstart / Sistema puesta en marcha

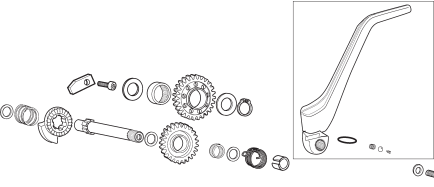

pag. 49 - 50

**15** Ensemble / Ignition / Encendido

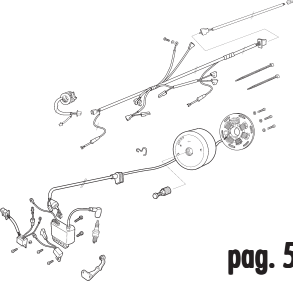

pag. 51 - 52

**16** Transmission primaire / Primary drive / Transmisión primaria

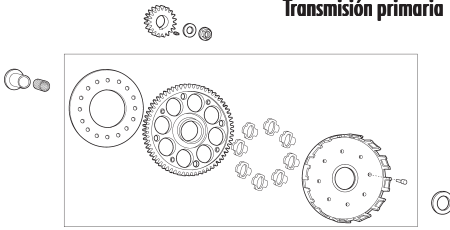

pag. 53 - 54

**17** Carburateur / Carburetor / Carburador

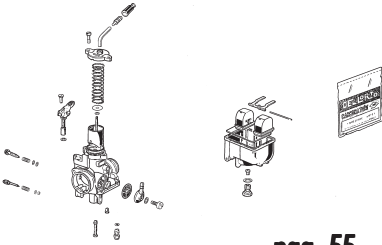

pag. 55 - 58

1

Cadre / Frame / Chasis

**SHERCO**  
Motorcycles

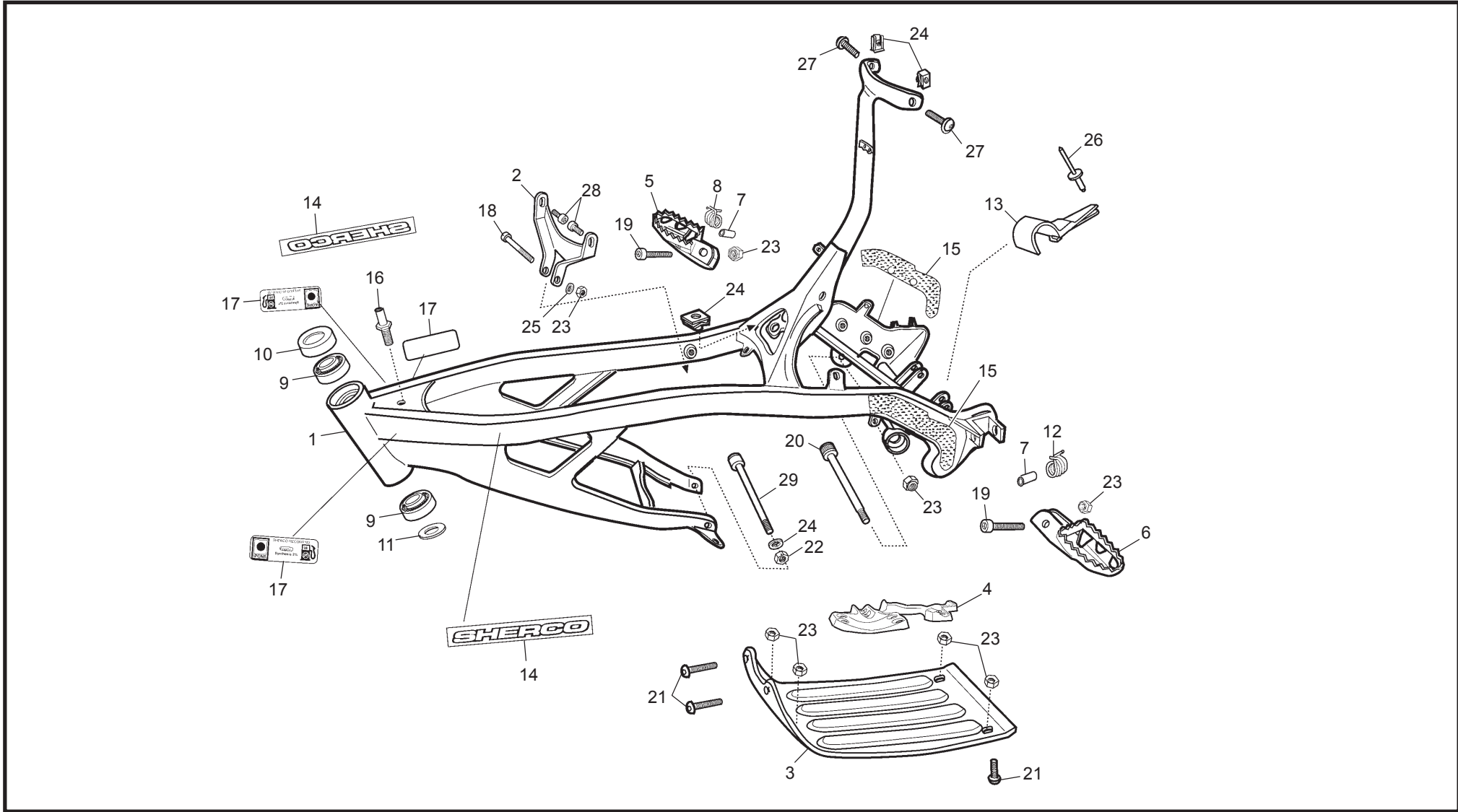

**Cadre / Frame / Chasis**

POS.	1.2	2.0	2.5	2.9	FRANÇAIS	ENGLISH	ESPAÑOL
1	C020	C020	C391	C391	CADRE	FRAME	CHASIS
2	M225	M225	C002	C002	PATE FIXATION CYLINDRE	CYLINDER SUPPORT	SOPORTE CILINDRO
3	C003	C003	C003	C003	SABOT	BASH PLATE	PLACA MOTOR
4	C578	C578	C578	C578	CAOUTCHOUC MOTEUR	BASH PLATE RUBBER	CAUCHO PLACA MOTOR
5	C005	C005	C005	C005	REPOSE PIED DROITE	RIGHT FOOTREST	ESTRIBERA DERECHA
6	C006	C006	C006	C006	REPOSE PIED GAUCHE	LEFT FOOTREST	ESTRIBERA IZQUIERDA
7	C007	C007	C007	C007	ENTRETOISE REPOSE PIED	FOOTREST BUSHING	CASQUILLO ESTRIBERA
8	C008	C008	C008	C008	RESSORT REPOSE PIED DROITE	RIGHT FOOTPEG	MUELLE ESTRIBERA DERECHA
9	C009	C009	C009	C009	ROULEMENT COLONNE DIRECTION	STEERING BEARING	COJINETE DIRECCIÓN R32004
10	C010	C010	C010	C010	BAGUE DE PROTECTION HAUTE PLASTIC	PLASTIC DUST COVER	GUARDA POLVO SUPERIOR PLÁSTICO
11	C011	C011	C011	C011	BAGUE DE PROTECTION BASSE	WASHER	GUARDA POLVO INFERIOR
12	C012	C012	C012	C012	RESSORT DE REPOSE PIED GAUCHE	LEFT FOOTPEG SPRING	MUELLE ESTRIBERA IZQUIERDA
13	C013	C013	C013	C013	PATIN CHAINE CADRE	SWINGARM CHAIN PROTECTOR	PATÍN CADENA CUADRO
14	C357	C357	C357	C357	ADESIF SHERCO RESINE	SHERCO DECAL	ADHESIVO CHASIS SHERCO GOTA
15	C341	C341	C341	C341	ADESIF PROTECTION CADRE PAIRE	STICKER PROTECTOR PAIR	ADHESIVO PROT. CHASIS JUEGO
16	C019	C019	C019	C019	VIS SPECIALE BOBINE/ CADRE/ RESERV	SPECIAL SCREW (elec box holder)	TORNILLO ESPECIAL BOBIN/CHASIS
17	C393	C393	C393	C393	ADESIF IPONE	STICKER IPONE	ADHESIVO IPONE
18	M263	M263	M263	M263	VIS CHC 8x40	SCREW CHC 8x40	TORNILLO M8X40 DIN 912
19	M264	M264	M264	M264	VIS CHC 8x45	SCREW CHC 8x45	TORNILLO M8X45 DIN 912
20	M266	M266	M266	M266	VIS CHC 8x80	SCREW CHC 8x80	TORNILLO M8X80 DIN 912
21	M301	M301	M301	M301	VIS FHC 8x20	SCREW FHC 8x20	TORNILLO M8X20 DIN 7991
22	M304	M304	M304	M304	ECROU NYLSTOP M10	NUT NYLSTOP M10	TUERCA NYLSTOP M10
23	M305	M305	M305	M305	ECROU NYLSTOP M8	NUT NYLSTOP M8	TUERCA NYLSTOP M8
24	M308	M308	M308	M308	ECROU CLIP M6	NUT CLIP M6	TUERCA CLIP M6



**1****Cadre / Frame / Chasis**

POS.	1.2	2.0	2.5	2.9	FRANÇAIS	ENGLISH	ESPAÑOL
25	M316	M316	M316	M316	RONDELLE x 8	WASHER x 8	ARANDELA X 8 DIN 125 B
26	M341	M341	M341	M341	RIVET 4,8X16	RIVET 4.8x16	REMACHE 4.8X16 ALA ANCHA
27	M345	M345	M345	M345	VIS BHC 6X12 CAROSSERIE	SCREW	TORNILLO CARROCERÍA M6X12
28	M344	M344	M344	M344	VIS CHC 8X16 TETE BASSE	SCREW M8X16 DIN 6912	TORNILLO M8X16 DIN 6912
29	M296	M296	M296	M296	AXE MOTEUR AV	FRONT ENGINE BOLT	TORNILLO MOTOR

**2**

**Plastiques / Plastics / Plásticos**

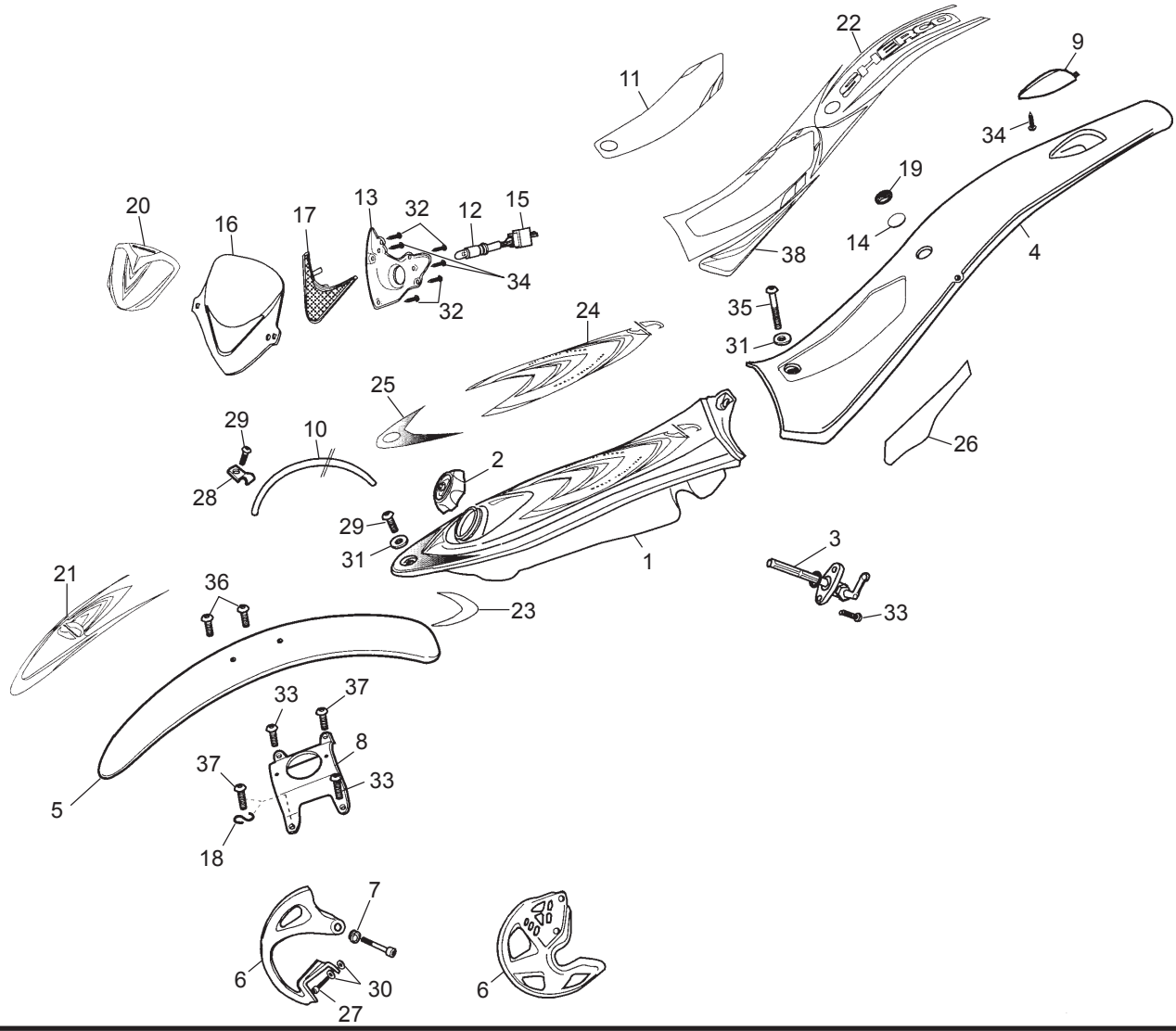



**2**

**Plastiques / Plastics / Plásticos**

POS.	1.2	2.0	2.5	2.9	FRANÇAIS	ENGLISH	ESPAÑOL
1	C383	C383	C383	C383	RESERVOIR ESSENCE	FUEL TANK	DEPÓSITO GASOLINA
2	C022	C022	C022	C022	BOUCHON ESSENCE	PETROL CAP	TAPÓN GASOLINA
3	C023	C023	C023	C023	ROBINET ESSENCE	PETROL TAP	GRIFO GASOLINA
4	S242	S242	S242	S242	GARDE BOUE ARRIERE	REAR MUDGUARD	GUARDABARROS TRASERO
5	S241	S241	S241	S241	GARDE BOUE AVANT	FRONT MUDGUARD	GUARDABARROS DELANTERO
6	C030	C030	C315	C315	PARE DISQUE	DISC COVER	PROTECTOR DISCO
7	C031	C031	C031	C031	ENTRETOISE PARE DISQUE	SPACER DISC COVER	SEPARADOR CUBREDISCOS DELANTERO
8	C301	C301	C301	C301	ARCEAU SUPPORT GARDE BOUE	F/MUDGUARD HOLDER	PUENTE SUSPENSIÓN
9	C064	C064	C064	C064	FEU ARRIERE	REAR LIGHT	LUZ TRASERA
10	C043	C043	C043	C043	DURITE ESSENCE	PETROL HOSE	TUBO GASOLINA
11	C342	C342	C342	C342	SELLE	SEAT	SILLÍN
12	C067	C067	C067	C067	AMPOULE AVANT	FRONT LIGHT BULB	BOMBILLA FARO DELANTERO
13	C062	C062	C062	C062	INT. PLAQUE PHARE NOIR	FRONT PLATE BACK HOLDER	INT. PLACA FARO
14	C308	C308	C308	C308	MOUSSE DOUBLE FACE RONDE	MUDGARD FOAM STICKER	ESPUMA ADH. REDONDO DOBLE CARA
15	C066	C066	C066	C066	FAISEAU ELECTRIQUE PLAQUE PHARE	HEADLIGHT WIRING HARNESS	INSTALACIÓN DELANTERA
16	S243	S243	S243	S243	PLAQUE PHARE	PLASTIC LIGHT COVER	PLACA FARO
17	C068	C068	C068	C068	OPTIQUE	HEADLIGHT LENSE	ÓPTICA COMPLETA
18	R136	R136	R136	R136	GUIDE RESSORT FOURCHE	F/ BRAKE HOSE CLIP	GUÍA LATIGUILLO
19	C355	C355	C355	C355	AD RESINE SHERCO PARE BOOUE AR	SHERCO STICKER RESINE	ADHESIVO RESINA SHERCO
20	C336	C336	C336	C336	AD PLAQUE FARE	FRONT LIGHT STICKER	AD PLACA FARO
21	C335	C335	C335	C335	AD GB AVANT	FRONT MUDGARD STICKER	AD GB DELANTERO
22	C354	C354	C354	C354	AD GB ARRIERE	REAR MUDGARD TOP STICKER	AD GB TRASERO
23	C339	C339	C339	C339	AD GB AVANT INFERIEUR	LOW FRONT MUDGARD STICKER	AD GB DELANT. INF.
24	C447	C447	C447	C447	AD RESERVOIR CENTRAL	CENTRAL PETROL TANK STICKER	AD DEPÓSITO CENTRAL

**2**

**Plastiques / Plastics / Plásticos**

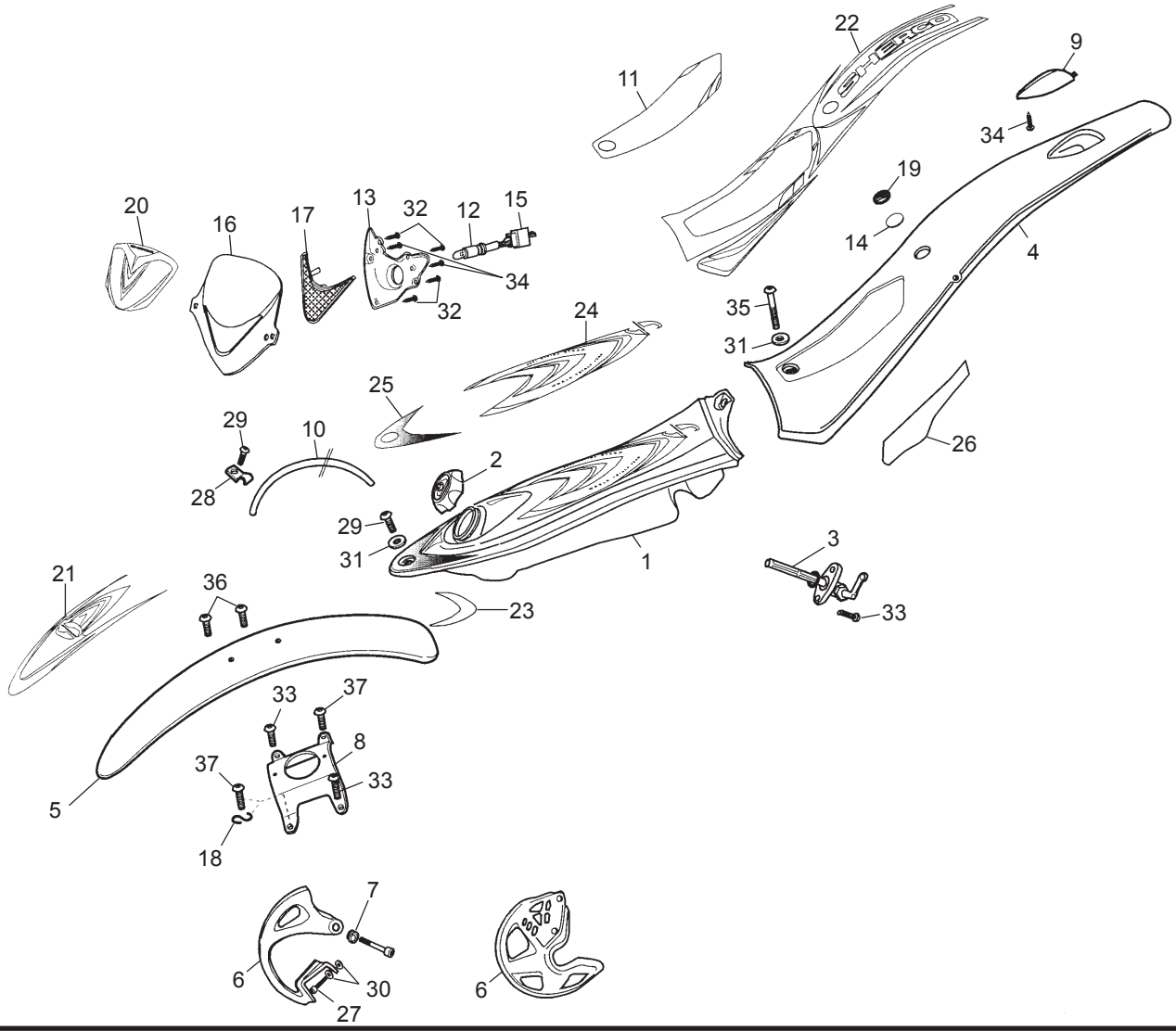

**Plastiques / Plastics / Plásticos**

POS.	1.2	2.0	2.5	2.9	FRANÇAIS	ENGLISH	ESPAÑOL
25	C340	C340	C340	C340	AD RESERVOIR SUPERIEUR	UPPER PETROL TANK STICKER	AD DEPÓSITO SUPERIOR
26	C392	C392	C392	C392	ADH PROTECTEUR TERMIQUE	HEAT RESISTANT STICKER	PROTECTOR TÉRMICO
27	M267	M267	M267	M267	VIS CHC 4x16	SCREW VIS CHC 4x16	TORNILLO M4X16 DIN 912
28	M273	M273	M273	M273	CAVALIER NORMA BSL1x8	CAVALIER NORMA BSL 1x8	BRIDA NORMA BSL1X8
29	M282	M282	M282	M282	VIS BHC 6x10	SCREW BHC 6x10	TORNILLO M6X10 ULS
30	M318	M318	M318	M318	RONDELLE 4x12	WASHER 4x12	ARANDELA 4X12X1 DIN 9021
31	M321	M321	M321	M321	RONDELLE 6x18	WASHER 6x18	ARANDELA 6X18X1.5 DIN 9021
32	M336	M336	M336	M336	VIS TOLE 2.9X9.5	SCREW 2.9X9.5	TORNILLO CHAPA 2.9X9.5
33	M289	M289	M289	M289	ULS VIS BHC M6X12	SCREW M6X12	TORNILLO M6X12
34	M342	M342	M342	M342	VIS TOLE 3.5X9.5	SCREW 3.5X9.5	TORNILLO CHAPA 3.5X9.5
35	M343	M343	M343	M343	VIS BCH 6X35	SCREW 6X35	TORNILLO M6X36 ULS
36	M278	M278	M278	M278	BHC 5X10	SCREW BHC 5X10	TORNILLO M5X10 ULS
37	M283	M283	M283	M283	VIS BHC 6X16	SCREW BHC 6X16	TORNILLO 6X16 ULS
38	C356	C356	C356	C356	AD LATERAL PEIRE GB ARRIERE	REAR MUDGARD SIDE STICKER	AD LATERAL GB TRASERO JUEGO
39	C307	C307	C307	C307	AD RESERVE COMPETITION	ADVISE STICKER	AD RESERVADO COMPETICIÓN



**Guidon / Handlebar / Manillar**

POS.	1.2	2.0	2.5	2.9	FRANÇAIS	ENGLISH	ESPAÑOL
1	C070	C070	C070	C070	GUIDON	HANDLEBAR	MANILLAR
2	C074	C074	C074	C074	COMMANDE DE GAZ	THROTTLE CONTROL	MANDO DE GAS
3	C075	C075	C075	C075	POIGNEE CAOUTCHOUC PAIRE	GRIPS SET	JUEGO EMPUÑADURAS
4	C076	C076	C076	C076	CABLE DE GAZ	THROTTLE CABLE	CABLE DE GAS
5	R023	R023	R023	R023	KIT REP. EMBRAYAGE	CLUTCH SLAVE CYLINDER REPAIR KIT	KIT REPARACIÓN EMBRAGUE
6	R024	R024	R024	R024	TORIQUE EMBRAYAGE	CLUTCH SLAVE CYLINDER O-RING	TÓRICA EMBRAGUE
7	R030	R030	R030	R030	POMPE EMB. CPL	CLUTCH MASTER CYLINDER ASSEMBLY	CONJUNTO BOMBA EMBRAQUE
8	R031	R031	R031	R031	LEJIER EMB SEUL	CLUTCH LEVER	MANETA EMBRAGUE
9	R032	R032	R032	R032	RECEPTEUR EMB SEUL	CLUTCH SLAVE CYLINDER HOUSING	PINZA EMBRAGUE COMPLETA
10	R033	R033	R033	R033	DURITE EMBRAYAGE / FREIN	CLUTCH HOSE / BRAKE	LATIGUILLO EMBRAGUE FRENO
11	M089	M089	M089	M089	GROUPE CPL. EMB.	COMPLETE CLUTCH HYDRAULIC KIT	GRUPO EMBRAGUE COMPLETO
12	R042	R042	R042	R042	CLIP PLAQUETTES	CALIPER SPRING CLIP	CLIP PASTILLAS
13	R207	R207	R207	R207	CONTACTEUR FREIN AVANT	BRAKE LIGHT SWITCH	INTERRUPTOR FRENO DELANTERO
14	R050	R050	C387	C387	ETRIER FREIN AVANT	FRONT CALIPER ASSY	PINZA FRENO DELANTERO
15	R051	R051	C389	C389	PLAQUETTES FREIN PAIRE	PAD BRAKE	JUEGO PASTILLAS FRENO
16	R052	R052	R234	R234	KIT REPARATION ETRIER	FRONT BRAKE CALIPER REPAIR KIT	KIT REPARACIÓN PINZA
17	R053	R053	R053	R053	KIT REPARATION POMPE FREIN	FRONT BRAKE MASTER CYLIN. REPAIR KIT	KIT REPARACIÓN BOMBA DELANTERO
18	R055	R055	R055	R055	LEVIER FREIN AVANT SEUL	FRONT BRAKE LEVER	MANETA FRENO
19	R056	R056	R056	R056	POMPE FREIN AV CPL	FRONT BRAKE MASTER CYLIN. ASSEMBLY	BOMBA FRENO DELANTERO
20	R057	R057	R057	R057	PURGEUR ETIER AVANT	BLEED SCREW	SANGRADOR DELANTERO
21	R058	R058	R058	R058	CAPUCHON VIS DE PURGE	BLEED SCREW COVER	TAPÓN SANGRADOR
22	R059	R059	R059	R059	VIS RACCORD M10 x 21	FRONT CALIPER BANJO BOLT	TORNILLO RACORD M10X21
23	R043	R043	R043	R043	GUIDE ETRIER	WIRE GUIDE LOOP	GANCHO LATIGUILLO
24	R044	R044	R044	R044	VIS BANJO	BANJO BOLT	TORNILLO RACORD ULS

**3**

**Guidon / Handlebar / Manillar**

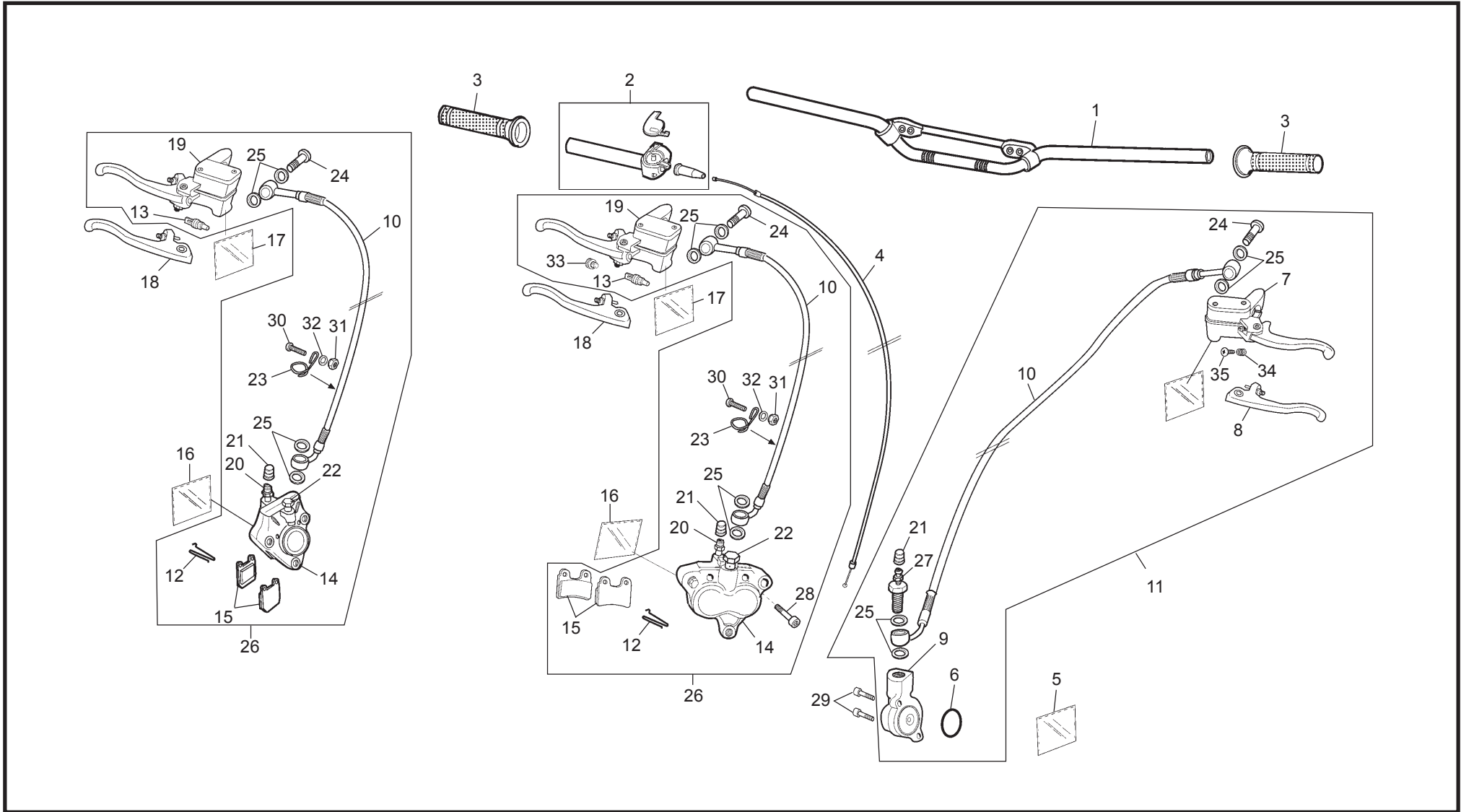

**3**

**Guidon / Handlebar / Manillar**

POS.	1.2	2.0	2.5	2.9	FRANÇAIS	ENGLISH	ESPAÑOL
25	R074	R074	R074	R074	JOINT	COPPER O-RING	ARANDELA BANJO
26	C210	C210	C318	C318	GROUPE FREIN AVANT CPL	FRONT BRAKE HYDRAULIC ASSEMBLY	GRUPO FRENO DEL COMPLETO
27	R068	R068	R068	R068	PURGEUR RACORD	BLEED SREW	SANGRADOR RACORD
28	.....	.....	R236	R236	AXE ETRIER FREIN AV D. PISTON	PIN FRONT CALIPER DL.PISTON	EJE PINZA FRENO DEL DOBLE PISTÓN
29	M252	M252	M252	M252	VIS CHC 6x20	SCREW CHC 6x20	TORNILLO M6X20 DIN 912
30	M283	M283	M283	M283	VIS BHC 6x16	SCREW BHC 6x16	TORNILLO M6X16 ULS
31	M306	M306	M306	M306	ECROU NYLSTOP M6	NUT NYLSTOP M6	TUERCA NYLSTOP M6
32	M317	M317	M317	M317	RONDELLE x 6	WASHER x 6	ARANDELA X 6 DIN 125 B
33	R366	R366	R366	R366	RACORD	BUSHING FRONT BRAKE LIGHT SWITCH	SOPORTE INTERIOR FRENO
34	R367	R367	R367	R367	RESSORT	SPRING	MUELLE MANETA EMBRAGUE
35	R368	R368	R368	R368	VIS REGULATION	SCREW	TORNILLO TENSOR MANETA EMBRAGUE

**4**

**Radiateur / Radiator / Radiador**

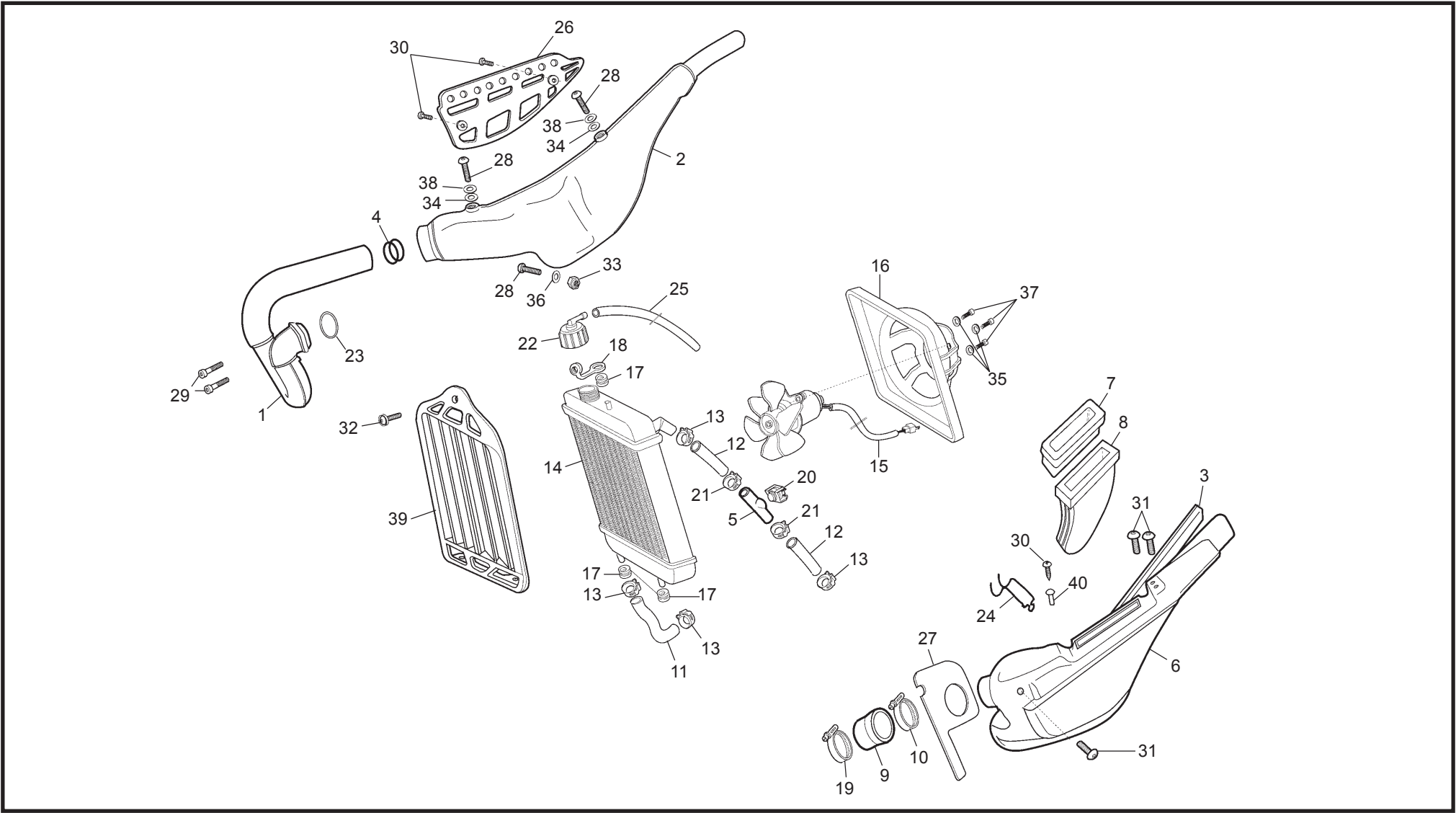

**Radiateur / Radiator / Radiador**

POS.	1.2	2.0	2.5	2.9	FRANÇAIS	ENGLISH	ESPAÑOL
1	C305	C305	C080	C080	TUBE ECHAPPEMENT	EXHAUST PIPE	CURVA DE ESCAPE
2	C103	C103	C384	C384	POT CENTRAL	MIDDLE SILENCER	SILENCIADOR CENTRAL
3	C303	C303	C303	C303	CAOUTCHOUC FILTRE-POT	FITTING RUBBER	ESPUMA FILTRO ESCAPE
4	C104	C104	C104	C104	JOINT TORIQUE POT CENTRAL 44x3.5	O-RING MIDDLE SILENCER	JUNTA TÓRICA SILEN.CENTRAL 44X3,5
5	C126	C126	C126	C126	SUPPORT DE THERMOCONTACT	THERMOSTAT SUPPORT T-PIECE	SOPORTE TERMOSTATO
6	C026	C026	C026	C026	BOITIER FILTRE AIR	AIR FILTER BOX	CAJA FILTRO
7	C107	C107	C107	C107	COUVERCLE FILTRE AIR	AIR FILTER BOX COVER	TAPA FILTRO
8	C108	C108	C108	C108	MOUSSE DE FILTRE	AIR FILTER ELEMENT	ESPUMA DE FILTRO
9	M224	M224	C109	C109	RACCORD FILTRE CARBURETEUR	MANIFOLD FILTER/ CARBURETOR	TOBERA FILTRO/CARBURADOR
10	C110	C110	C110	C110	COLLIER NORMA 32/50	HOSE CLAMP	ABRAZADERA NORMA 32/50
11	C112	C112	C112	C112	DURITE POMPE EAU RADIATEUR	RUBBER HOSE WATERPUMP/RADIATOR	TUBO GOMA BOMBA/RADIADOR
12	C130	C130	C130	C130	DURITE CULASSE RADIATEUR	RUBBER HOSE RADIATOR	TUBO GOMA CULATA RADIADOR
13	C114	C114	C114	C114	COLLIER DE DURITE NORMA VERT 21	HOSE CLAMP	ABRAZADERA 21 VERDE
14	C115	C115	C115	C115	RADIATEUR	RADIATOR	RADIADOR
15	C116	C116	C313	C313	VENTILATEUR	FAN	VENTILADOR
16	C117	C117	C117	C314	SUPPORT DE VENTILATEUR	FAN SUPPORT	SOPORTE VENTILADOR
17	C118	C118	C118	C118	SILENT-BLOC RADIATEUR	SILENT-BLOC RADIATOR	SILENT-BLOC RADIADOR
18	C119	C119	C119	C119	PATE FIXATION RADIATEUR	HOLDER (silent bloc radiator)	SOPORTE FIJACIÓN RADIADOR
19	C120	C120	C120	C120	COLLIER NORMA 30/45	HOSE CLAMP	ABRAZADERA NORMA 30/45
20	C127	C127	C127	C127	SONDE THERMOSTATIQUE	THERMOSTAT	TERMOSTATO
21	C029	C029	C029	C029	COLLIER DE DURITE NORMA VIOLET 19	HOSE CLAMP	ABRAZADERA 19 VIOLETA
22	R046	R046	R046	R046	BOUCHON DE RADIATEUR	RADIATOR CAP	TAPÓN RADIADOR
23	C122	C122	C122	C122	JOINT CUIVRE 38X44X2,5	EXHAUST GASKET	JUNTA COBRE SALIDA CILINDRO
24	C394	C394	C394	C394	RESSORT COUVERCLE FILTRE	AIRBOX RETAINER CLIP	MUELLE TAPA FILTRO

**4**

**Radiateur / Radiator / Radiador**

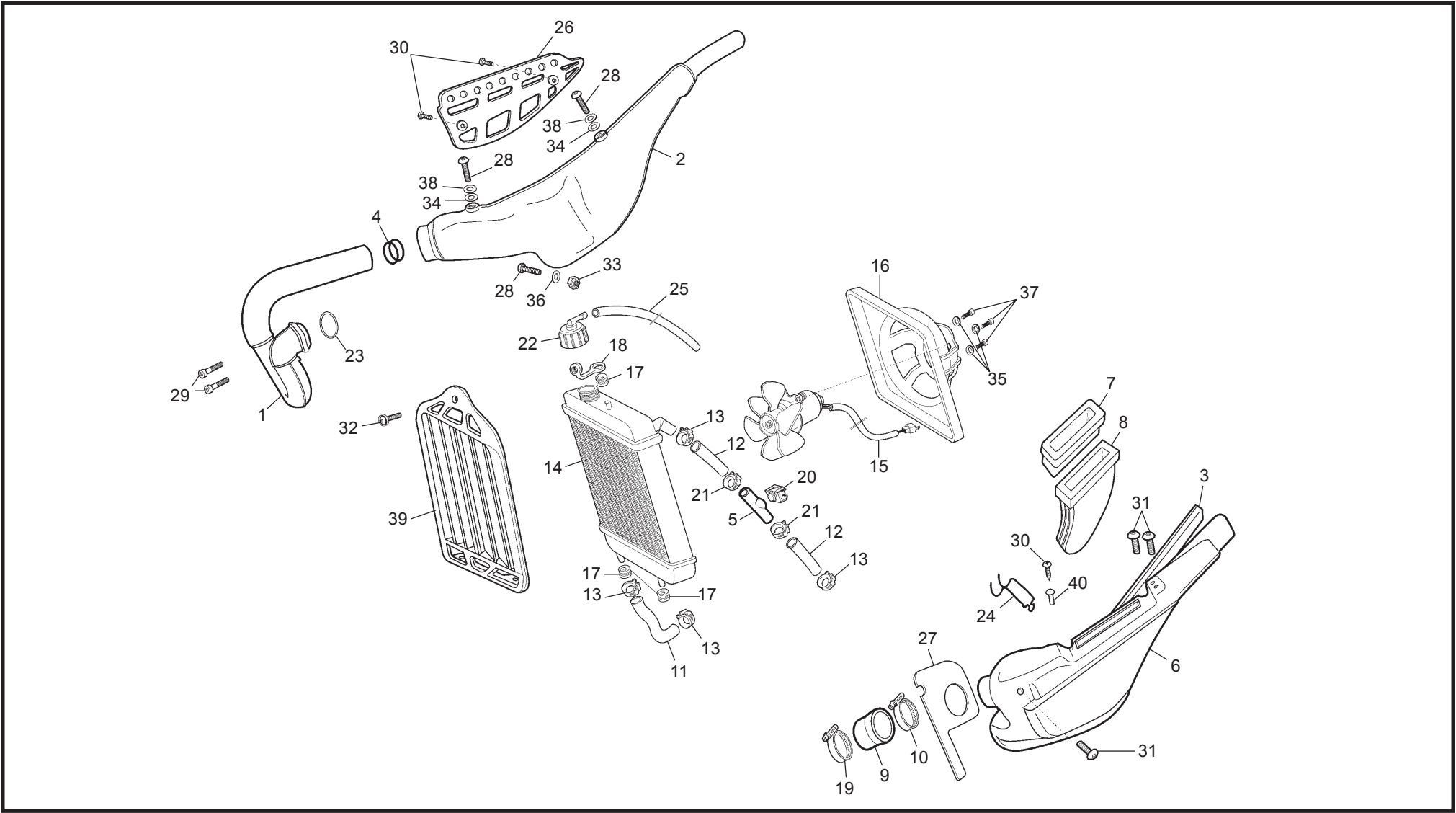

**Radiateur / Radiator / Radiador**

POS.	1.2	2.0	2.5	2.9	FRANÇAIS	ENGLISH	ESPAÑOL
25	C125	C125	C125	C125	DURITE RADIATEUR	RADIATOR OVERFLOW HOSE	TUBO DRENAJE RADIADOR
26	C316	C316	C316	C316	PROTECTEUR ECHAPEMENT	EXHAUST PROTECTOR	PROTECTOR ESCAPE
27	C459	C459	C459	C459	DEFLECTEUR FILTRE AIR	AIR BOX DEFLECTOR	DEFLECTOR CAJA FILTRO
28	M251	M251	M251	M251	VIS CHC 6x16	SCREW CHC 6x16	TORNILLO M6X16 DIN 912
29	M252	M252	M252	M252	VIS CHC 6x20	SCREW CHC 6x20	TORNILLO M6X20 DIN 912
30	M278	M278	M278	M278	VIS TOLE 3.9X16	SCREW PLATE 3.9X16	TORNILLO CHAPA 3.9X16
31	M282	M282	M282	M282	VIS BHC 6x10	SCREW BHC 6x10	TORNILLO M6X10 ULS
32	M283	M283	M283	M283	VIS BHC 6x16	SCREW BHC 6x16	TORNILLO M6X16 ULS
33	M306	M306	M306	M306	ECROU NYLSTOP M6	NUT NYLSTOP M6	TUERCA NYLSTOP M6
34	M317	M317	M317	M317	RONDELLE x 6	WASHER x 6	ARANDELA X 6 DIN 125 B
35	M318	M318	M318	M318	RONDELLE 4x12	WASHER 4x12	ARANDELA 4X12X1 DIN 9021
36	M321	M321	M321	M321	RONDELLE M6X18	WASHER 6X18	ARANDELA M6X18
37	C358	C358	C358	C358	VIS CHC 4X6	SCREW CHC 4X6	TORNILLO 4X6 DIN 912
38	M274	M274	M274	M274	RONDELLE GROSVER X6 DIN 67985	WASHER 6 DIN 67985	ARANDELA DENTADA 6 DIN 67985
39	C035	C035	C035	C035	GRIME RADIATEUR	RADIATOR PROTECTOR	RESINA RADIADOR
40	M377	M377	M377	M377	RIVET PLASTIC	RIVET PLASTIC	REMACHE PLÁSTICO

**5**

**Bras oscillant / Swingarm / Basculante**

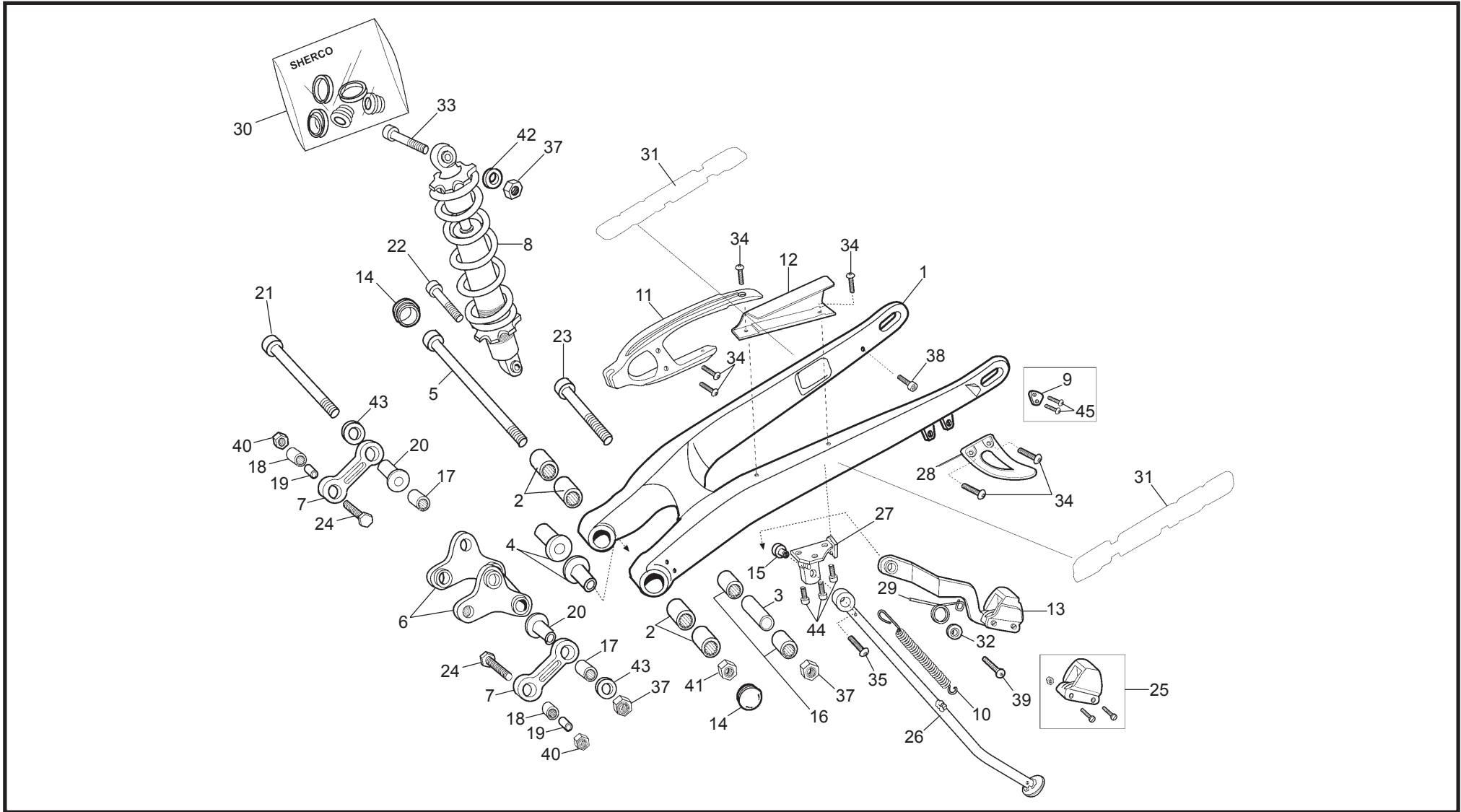

**5**

**Bras oscillant / Swingarm / Basculante**

POS.	1.2	2.0	2.5	2.9	FRANÇAIS	ENGLISH	ESPAÑOL
1	C150	C150	C448	C448	BRAS OSCILLANT	SWINGARM	BASCULANTE
2	C151	C151	C151	C151	DOUILLE AIGUILLE BRAS HK 20x20x2RS	BEARING HK 20x20x2RS	CASQUILLO AGUJAS BASCUL. HK2020/RS
3	C152	C152	C152	C152	ENTRETOISE SUSPENSION	SPACER SUSPENSION	SEPARADOR SUSPENSIÓN
4	C153	C153	C153	C153	ENTRETOISE ARTICULATION BRAS	SPACER SWINGARM	CASQUILLO EJE BASCULANTE
5	C154	C154	C154	C154	AXE BRAS OSCILLANT	ALUMINIUM SWINGARM AXLE	EJE BASCULANTE ALUMINIO
6	C156	C156	C156	C156	BIELETTE DELTA	REAR SUSPENSION DELTA LINK	TRAPECIO SUSPENSIÓN
7	C157	C157	C157	C157	BIELETTE TIRANT SIMPLE	REAR SUSPENSION LINK	BIELA SUSPENSIÓN
8	C268	C268	C268	C268	AMORTISSEUR	REAR SHOCK	AMORTIGUADOR
9	C159	C159	.....	.....	BUTEE POUR EXANTRIQUE	SNAIL CAM STOP	TOPE DE EXCÉNTRICAS
10	C161	C161	C161	C161	RESSORT DE BEQUILLE	SIDE STAND SPRING	MUELLE CABALLETE
11	C162	C162	C162	C162	PATIN DE CHAINE	CHAIN GUIDE PLATE	PATÍN CADENA
12	C163	C163	C163	C163	CARTER DE CHAINE	CHAIN PROTECTOR	CUBRECADENAS
13	C164	C164	C164	C164	TENDEUR DE CHAINE	CHAIN TENSIONER	TENSOR CADENA
14	C165	C165	C165	C165	BOUCHON AXE BRAS OSCILLANT	COVER SWING ARM AXLE	TAPÓN EJE BASCULANTE
15	C166	C166	C166	C166	VIS SPECIALE BEQUILLE	SIDE STAND SPECIAL BOLT	TORNILLO ESPECIAL CABALLETE
16	C167	C167	C167	C167	DOUILLE AIGUILLE BRAS/SUSP HK16202 RS	BEARING HK16202RS	CASQUILLO AGUJAS BASC. HK16202RS
17	C168	C168	C168	C168	DOUILLE AIGUILLE TIRANT HK 16162RS	LINKAGE BEARING	CASQ. AGUJAS BIELETA SUSP. HK16162RS
18	C169	C169	C169	C169	DOUILLE AIGUILLE TIRANT HK14162RS	BEARING HK14162RS	CASQ. AGUJAS BIELETA SUSP. HK14162RS
19	C170	C170	C170	C170	ENTRETOISE TIRANT	LINK SPACER	CASQUILLO BIELETA
20	C171	C171	C171	C171	ENTRETOISE TIRANT EPAULEE	LINK SPACER	CASQUILLO BIELETA CON ARANDELA
21	C172	C172	C172	C172	AXE 10x120	PIN 10x120	EJE 10X120
22	C173	C173	C173	C173	AXE 10x42	PIN 10x42	EJE 10X42
23	C174	C174	C174	C174	AXE 10x72	PIN 10x72	EJE 10X72
24	C175	C175	C175	C175	VIS HEXA TETE BASSE	SPECIAL HEAD HEX SCREW	TORNILLO HEXAG. CABEZA REBAJADA

**Bras oscillant / Swingarm / Basculante**

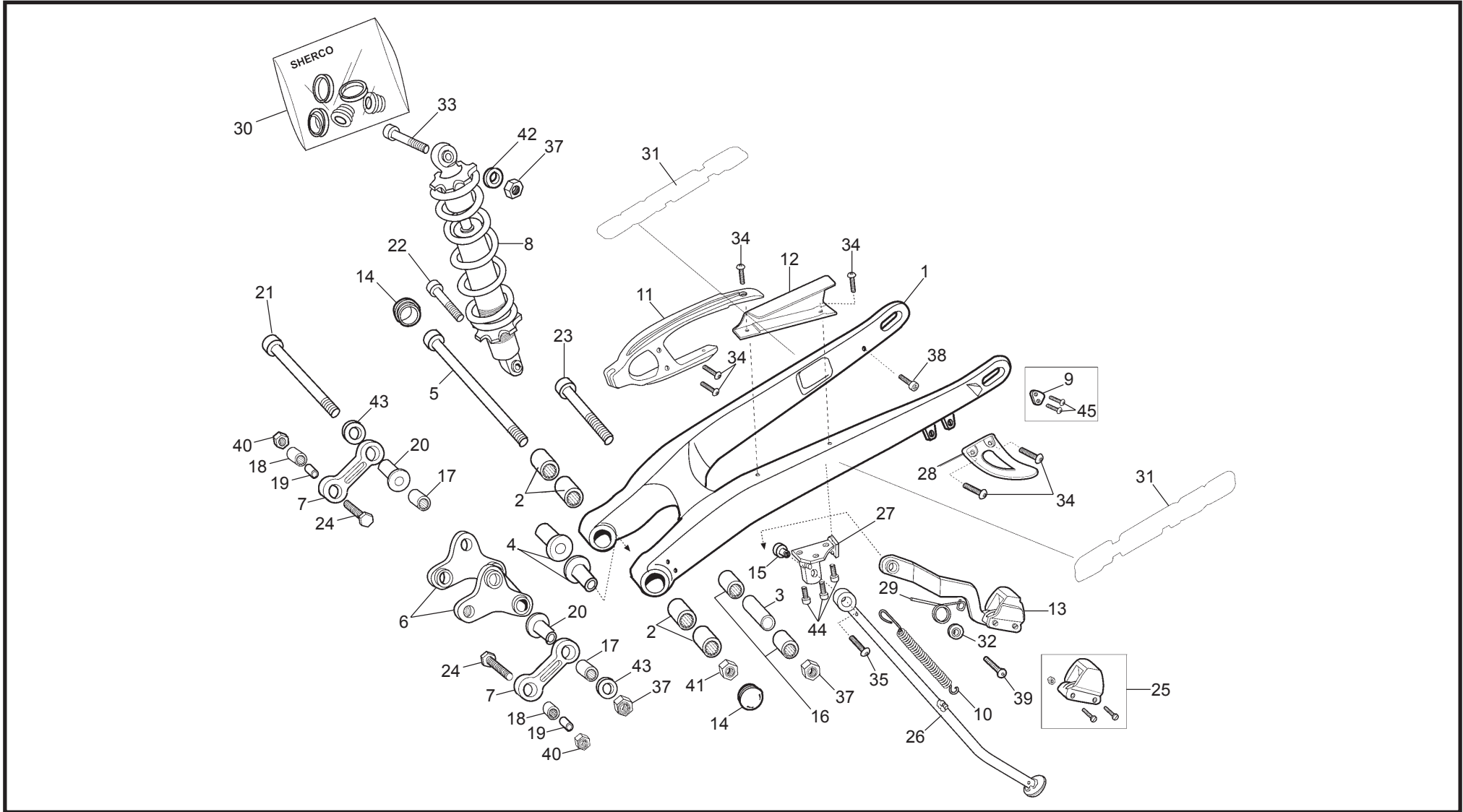

**5**

**Bras oscillant / Swingarm / Basculante**

POS.	1.2	2.0	2.5	2.9	FRANÇAIS	ENGLISH	ESPAÑOL
25	R047	R047	R047	R047	CAOUTCHOUC TENDEUR SEUL	CHAIN TENSIONER REPAIR KIT	GOMA TENSOR CADENA
26	S131	S131	S131	S131	BEQUILLE SEULE	SIDE STAND	CABALLETE
27	S132	S132	S132	S132	SUPPORT DE BEQUILLE	SIDE STAND MOUNTING BRACKET	SOPORTE CABALLETE
28	C177	C177	C177	C177	PROTECTEUR COURRONE	SPROCKET PROTECTOR	PROTECTOR CORONA
29	R205	R205	R205	R205	RESSORT TENDEUR DE CHANE	CHAIN TENSIONER SPRING	MUELLE TENSOR
30	R217	R217	R217	R217	KIT ROTULE AMORTISEUR	REAR SHOCK UPPER BUSHING REPAIR KIT	KIT ROTULA AMORTIGUADOR
31	C449	C449	C449	C449	ADESIF BRAS	SWINGARM STICKER	ADHESIVO BASCULANTE
32	R206	R206	R206	R206	ENTRETOISE TENDEUR DE CHAINE	SPACER CHAIN TENSIONER	CASQUILLO TENSOR CADENA
33	M259	M259	M259	M259	VIS CHC 10x50	SCREW CHC 10x50	TORNILLO M10X50 DIN 912
34	M278	M278	M278	M278	BHC 5x10	SCREW BHC 5x10	TORNILLO M5X10 ULS
35	M281	M281	M281	M281	VIS BHC 8x12	SCREW BHC 8x12	TORNILLO M8X12 ULS
36	M283	M283	M283	M283	VIS BHC 6x16	SCREW BHC 6x16	TORNILLO M6X16 ULS
37	M304	M304	M304	M304	ECROU NYLSTOP M10	NUT NYLSTOP M10	TUERCA NYLSTOP M10
38	M260	M260	M260	M260	VIS CHC 8x12	SCREW CHC 8x12	TORNILLO M8X12 DIN 912
39	M300	M300	M300	M300	VIS FHC 8x35	SCREW FHC 8x35	TORNILLO M8X35 DIN 7991
40	M305	M305	M305	M305	ECROU NYLSTOP M8	NUT NYLSTOP M8	TUERCA NYLSTOP M8
41	M310	M310	M310	M310	ECROU PLAT M14x150	NUT PLAT M14 x 150	TUERCA REBAJADA M14X150
42	M315	M315	M315	M315	RONDELLE x 10	WASHER x10	ARANDELA X 10 DIN 125 B
43	M320	M320	M320	M320	RONDELLE 10x30	WASHER 10x30	ARANDELA 10X30
44	M261	M261	M261	M261	VIS CHC M8X20	SCREW CHC 8X20	TORNILLO M8X20 DIN 912
45	M283	M283	.....	.....	VIS BHC 6x16	SCREW BHC M6x16	TORNILLO ULS M6x16

**6**

**Roue avant / Front wheel / Rueda delantera**

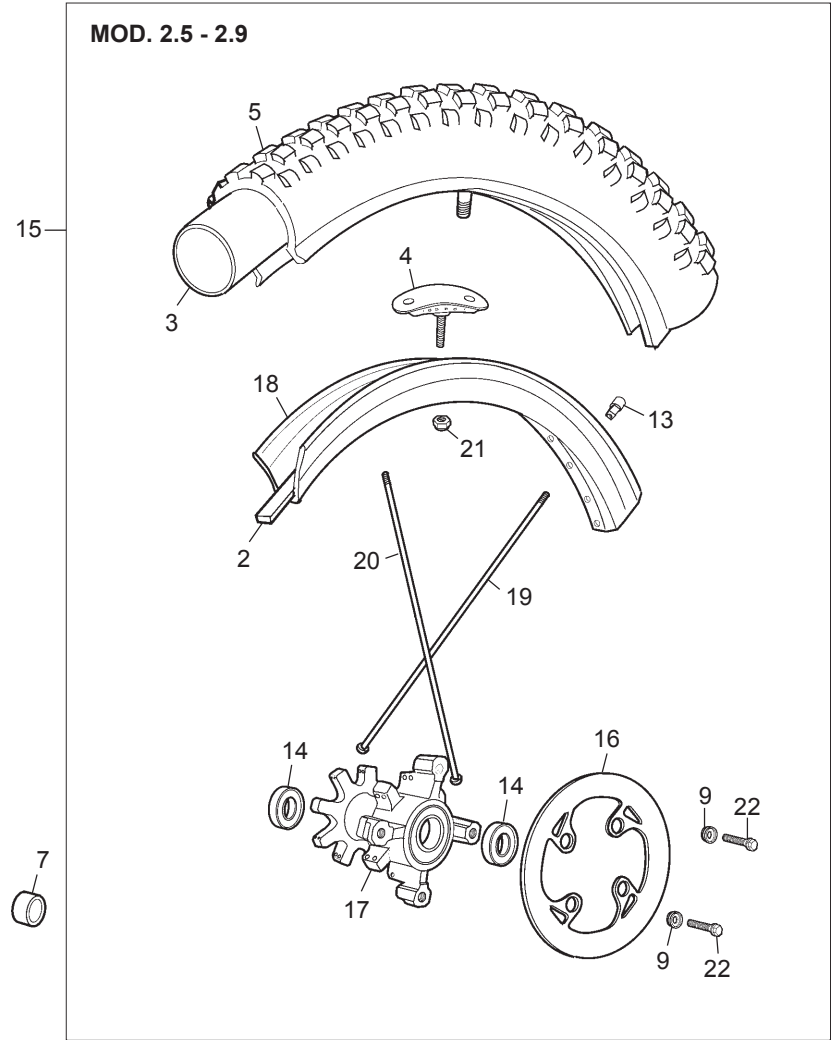
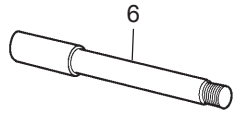
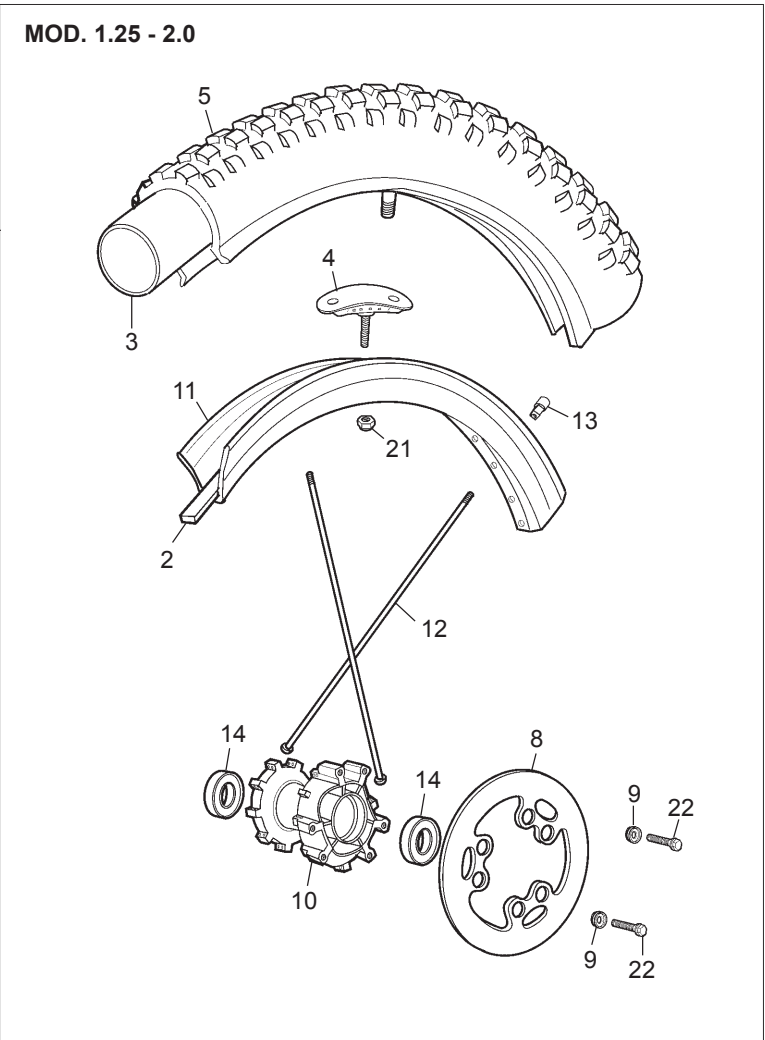

**6**

**Roue avant / Front wheel / Rueda delantera**

POS.	1.2	2.0	2.5	2.9	FRANÇAIS	ENGLISH	ESPAÑOL
1	C200	C200	.....	.....	ROUE AVANT COMPLETE	FRONT WHEEL ASSEMBLY	RUEDA DELANTERA COMPLETA
2	C201	C201	C201	C201	RUBAN FOUND DE JANTE R14025	RUBBER RIM BAND	GOMA PROTECCIÓN LLANTA
3	C202	C202	C202	C202	CHAMBRE A AIR 21AB	21 INCH INNER TUBE	CÁMARA 21
4	C203	C203	C203	C203	GRIPSTER	FRONT RIM LOCK	AGARRACUBIERTAS
5	C204	C204	C204	C204	PNEU AVANT 275x21	FRONT TIRE 2.75x21	NEUMÁTICO DELANTERO 2.75X21
6	C205	C205	C205	C205	AXE DE ROUE AVANT	FRONT WHEEL AXLE	EJE RUEDA DELANTERA
7	C206	C206	C333	C333	ENTRETOISE ROUE AVANT	FRONT WHEEL BUSHING	SEPARADOR EJE RUEDA DELANTERA
8	C208	C208	.....	.....	DISQUE FREIN AVANT	FRONT DISK	DISCO FRENO DELANTERO
9	C209	C209	C209	C209	ENTRETOISE DISQUE AVANT	SPACER DISC	SEPARADOR DISCO DELANTERO
10	R001	R001	.....	.....	MOYEU AVANT CPL	FRONT HUB	BUJE DELANTERO
11	R002	R002	.....	.....	JANTE AVANT	FRONT RIM	LLANTA DELANTERA
12	R003	R003	.....	.....	RAYON AVANT	FRONT SPOKE	RADIO DELANTERO
13	R048	R048	R048	R048	ECROU DE RAYON AVANT	FRONT SPOKE NIPPLE	TUERCA RADIO DELANTERO
14	R049	R049	R049	R049	ROULEMENT DE MOYEU 6004 2RS	FRONT HUB BEARING 6004 2RS	RODAMIENTO BUJE 6004 2RS
15	.....	.....	C324	C324	ROUE AVANT COMPLETE	FRONT WHEEL ASSEMBLY	RUEDA DELANTERA COMP.
16	.....	.....	C319	C319	DISQUE FREIN AVANT	FRONT DISK	DISCO FRENO DELANTERO
17	.....	.....	C320	C320	MOYEU AVANT CPL	FRONT HUB	BUJE DELANTERO
18	.....	.....	C378	C378	JANTE AVANT	FRONT RIM	LLANTA DELANTERA
19	.....	.....	C382	C382	RAYON AVANT	FRONT SPOKE	RADIO DELANTERO L256
20	.....	.....	C381	C381	RAYON AVANT	FRONT SPOKE	RADIO DELANTERO L259
21	M305	M305	M305	M305	ECROU NYLSTOP M8	NUT NYLSTOP M8	TUERCA NYLSTOP M8
22	M249	M249	C452	C452	VIS 6X20	SCREW 6X20	TORNILLO M6X20
23	M306	M306	M306	M306	ECROU NYLSTOP M6	NUT NYLSTOP M6	TUERCA NYLSTOP M6
24	.....	.....	.....	.....	ENTRETOISE ROUE AVANT GAUCHE	FRONT WHEEL SPACER LEFT	SEPARADOR RUEDA DEL. IZQ.

**7**

**Roue arriere / Rear wheel / Rueda trasera**

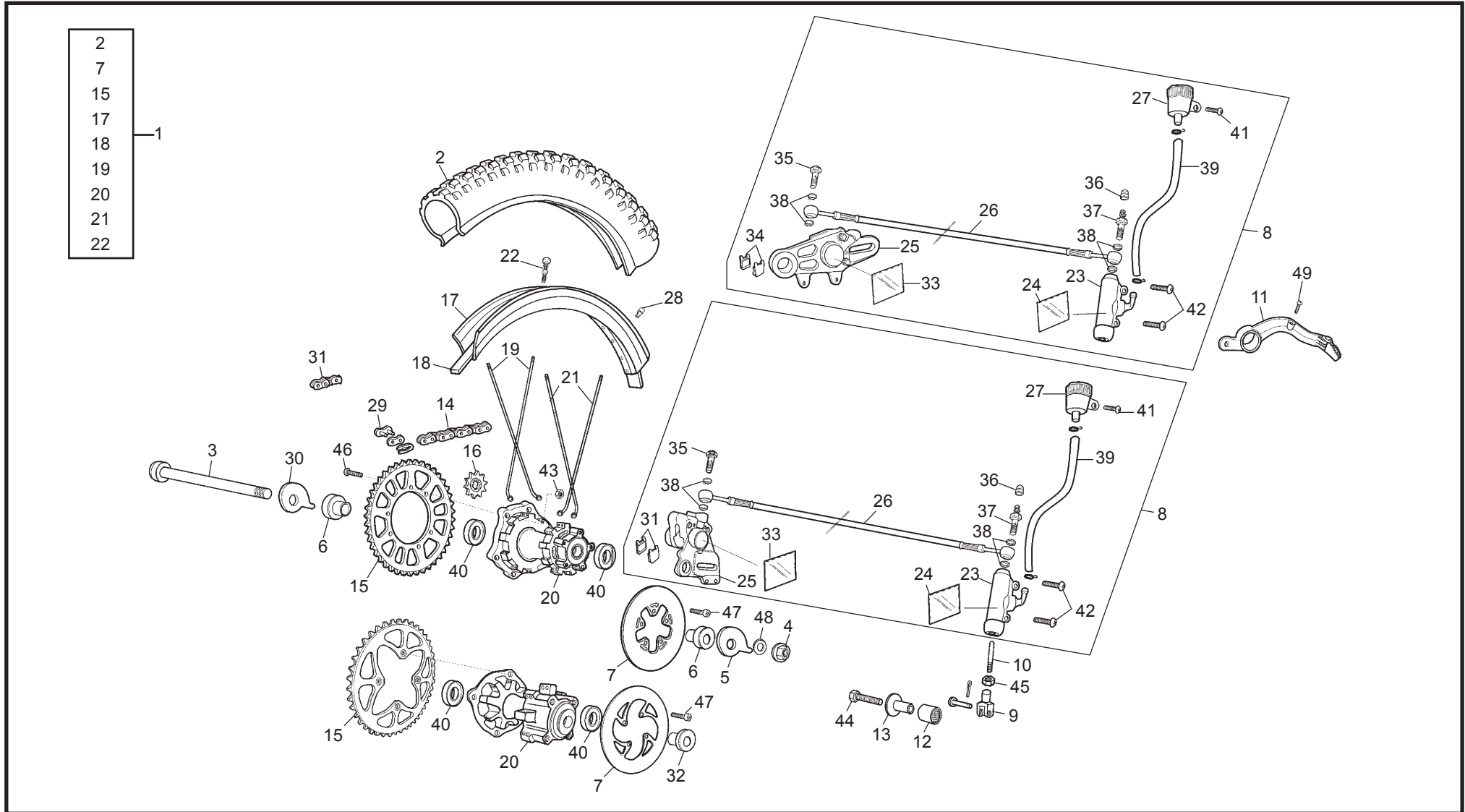

**Roue arriere / Rear wheel / Rueda trasera**

POS.	1.2	2.0	2.5	2.9	FRANÇAIS	ENGLISH	ESPAÑOL
1	C249	C249	C325	C325	ROUE ARRIERE COMPLETE	REAR WHEEL ASSEMBLY	RUEDA TRASERA COMPLETA
2	C251	C251	C251	C251	PNEU ARRIERE 400 x 18	REAR TIRE 400 X 18	NEUMÁTICO 400X18 TUBELESS
3	C252	C252	C326	C326	AXE ROUE ARRIERE	REAR WHEEL AXLE	EJE RUEDA TRASERA
4	C253	C253	C253	C253	ECROU ROUE ARRIERE	REAR AXLE NUT	TUERCA EJE TRASERO
5	C254	C254	C254	C254	EXENTRIQUE TENDEUR CHAINE	SNAIL CAM ADJUSTER	EXCÉNTRICA DERECHA
6	C255	C255	C255	C255	ENTRETOISE ROUE AR	REAR WHEEL SPACER	SEPARADOR RUEDA TRASERA
7	C257	C257	C322	C322	DISQUE FREIN ARRIERE	REAR DIC BRAKE	DISCO FRENO TRASERO
8	C258	C258	C321	C321	GROUPE FREIN ARRIERE CPL	REAR BRAKE COMPL. ASSY.	GRUPO FRENO TRASERO COMPLETO
9	C259	C259	C259	C259	CHAPE PEDALE FREIN	REAR BRAKE ROD	HORQUILLA PEDAL DE FRENO
10	C261	C261	C261	C261	TIGE FREIN ARRIERE	BRAKE ROD PIN	TIJA PEDAL FRENO TRASERO
11	C327	C327	C327	C327	PEDALE DE FREIN	REAR BRAKE PEDAL	PEDAL FRENO TRASERO
12	C263	C263	C263	C263	DOUILLE AIGUILLE PEDALE FREIN	BEARING HK 12162RS	CASQUILLO AGUJAS PEDAL DE FRENO
13	C264	C264	C264	C264	ENTRETOISE PEDALE DE FREIN	SPACER BRAKE PEDAL	CASQUILLO PEDAL DE FRENO
14	C265	C265	C310	C310	CHAINE	CHAIN	CADENA
15	M226	M226	C330	C330	COURRONE	REAR SPROCKET	CORONA
16	M227	M227	C267	C267	PIGNON	SPOCKET	PIÑÓN SALIDA
17	R004	R004	C377	C377	JANTE ARRIERE	REAR RIM	LLANTA TRASERA
18	R005	R005	R005	R005	FLAP DE ROUE ARRIERE	SPOKE SEALING STRIP	FLAP
19	R006	R006	C379	C379	RAYON ARRIERE	REAR SPOKE	RADIO TRASERO
20	R007	R007	C323	C323	MOYEU ROUE ARRIERE	REAR HUB	BUJE TRASERO CON RODAMIENTOS
21	R060	R060	C380	C380	RAYON AR	REAR SPOKE	RADIO TRASERO
22	R061	R061	R061	R061	VALVE	TUBELESS TIRE VALVE	VÁLVULA
23	R062	R062	C385	C385	POMPE FREIN AR	REAR MASTER CYLINDER	BOMBA FRENO TRASERO
24	R063	R063	R233	R233	KIT REP POMPE FREIN AR	REAR MASTER CYLINDER REPAIR KIT	KIT REP. BOMBA TRASERA
25	R064	R064	C386	C386	ETRIER FREIN AR	REAR CALIPER	PINZA FRENO TRASERA

**Roue arriere / Rear wheel / Rueda trasera**

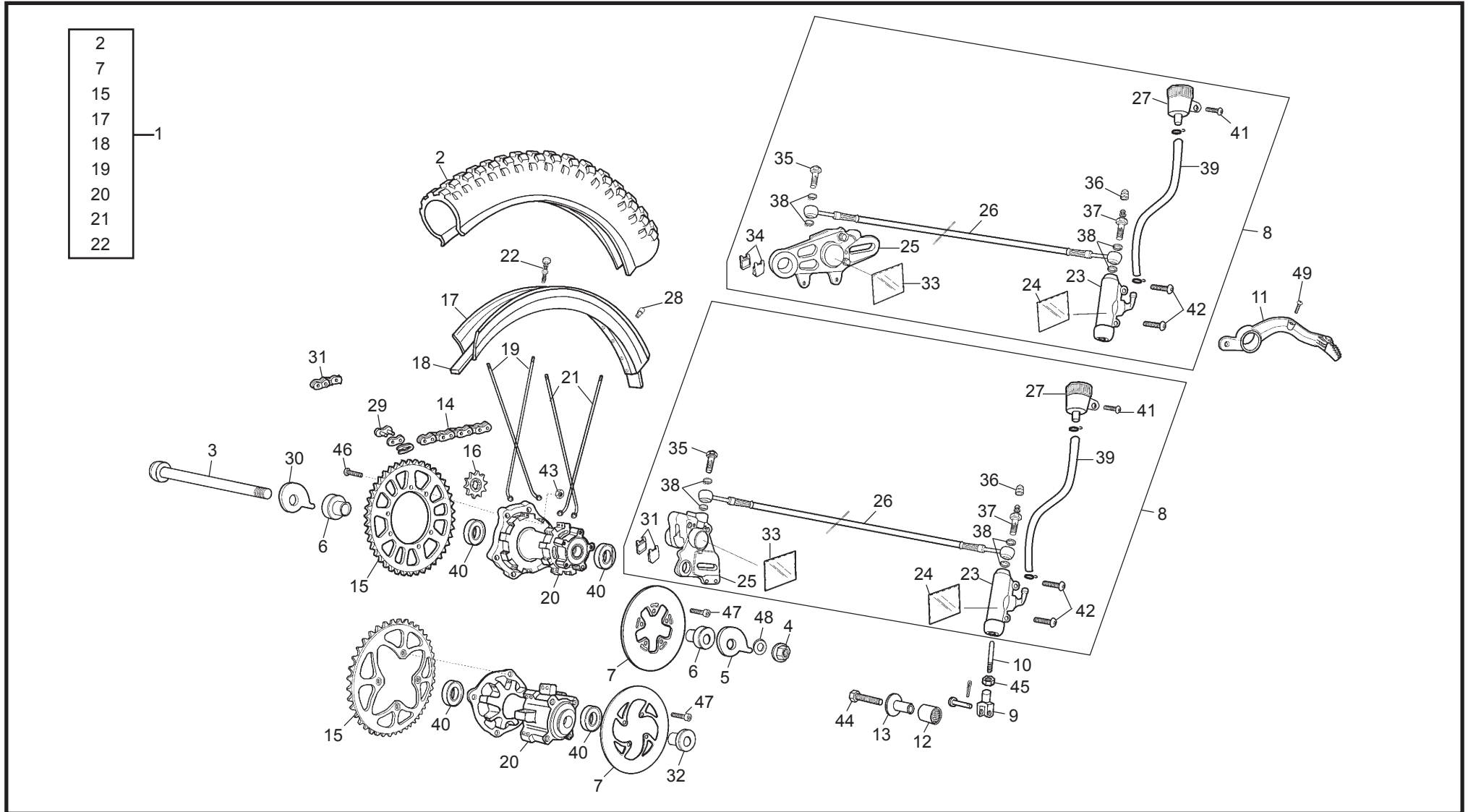

**Roue arriere / Rear wheel / Rueda trasera**

POS.	1.2	2.0	2.5	2.9	FRANÇAIS	ENGLISH	ESPAÑOL
26	R065	R065	C388	C388	DURITE FREIN AR	REAR BRAKE HOSE	LATIGUILLO FRENO TRASERO
27	R066	R066	R066	R066	BOCAL LIQUIDE FREIN	REAR BRAKE RESERVOIR	DEPÓSITO LIQUIDO FRENO
28	R067	R067	R067	R067	ECROU DE RAYON AR	REAR SPOKE NIPPLE	TUERCA RADIOS TRASEROS
29	R034	R034	R034	R034	ATACHE RAPIDE DE CHAINE	MASTER LINK	ENGANCHE CADENA
30	C256	C256	C256	C256	EXENTRIQUE GAUCHE TENDEUR CHAINE	SNAIL CAM ADJUSTER	EXCÉNTRICA IZQUIERDA
31	C304	C304	C304	C304	1/2 MAILLON DE CHAINE	CHAIN HALF LINK	MEDIA MALLA
32	.....	.....	C332	C332	ENTRETOISE ETROIT	SPACER BRAKE PEDAL	CASQUILLO ESTRECHO
33	R052	R052	R235	R235	KIT REPARATION ETRIER	CALIPER REPAIR KIT	KIT REPARACIÓN PINZA
34	R051	R051	C390	C390	PLAQUETTES FREIN PAIRE	BRAKE PAD	JUEGO PASTILLAS FRENO
35	R059	R059	R059	R059	VIS RACCORD M10X21	LINK SCREW M10X21	TORNILLO RACORD M10X21
36	R058	R058	R058	R058	CAPUCHON VIS DE PURGE	BLEED SCREW COVER	TAPÓN SANGRADOR
37	R057	R057	R057	R057	PURGEUR ETRIER AVANT	BLEED SCREW	SANGRADOR DELANTERO
38	R074	R074	R074	R074	JOINT	COPPER O-RING	ARANDELA BANJO
39	R069	R069	R069	R069	TUBE LIQUIDE L 210	HOSE, BRAKE RESER. TO MASTER CYLIN.	TUBO LIQUIDO L 210
40	R049	R049	R049	R049	ROULEMENT DE MOYEU 6004 2RS	BEARING HUB 6004 2RS	RODAMIENTO BUJE 6004 2RS
41	M282	M282	M282	M282	VIS BHC 6x10	SCREW BHC 6x10	TORNILLO M6X10 ULS
42	M284	M284	M284	M284	VIS BHC 6x25	SCREW BHC 6x25	TORNILLO M6X25 ULS
43	M305	M305	M305	M305	ECROU NYLSTOP M8	NUT NYLSTOP M8	TUERCA NYLSTOP M8
44	M303	M303	M303	M303	VIS HEXAG 8x25	SCREW HEXAG 8x25	TORNILLO M8X25 DIN 933
45	M309	M309	M309	M309	ECROU M6	M6 NUT	TUERCA M6
46	M287	M287	M287	M287	VIS BHC 8X22	SCREW BHC 8X22	TORNILLO CORONA M6X22 ULS
47	M249	M249	M249	M249	VIS 6X20	SCREW 6X20	TORNILLO M6X20
48	M314	M314	M314	M314	RONDELLE x 17	WASHER x17	ARANDELA X 17 DIN 125 B
49	C358	C358	C358	C358	VIS CHC 4X6	SCREW CHC 4X6	TORNILLO 4X6 DIN 912

**Fourche / Fork / Hoquilla**

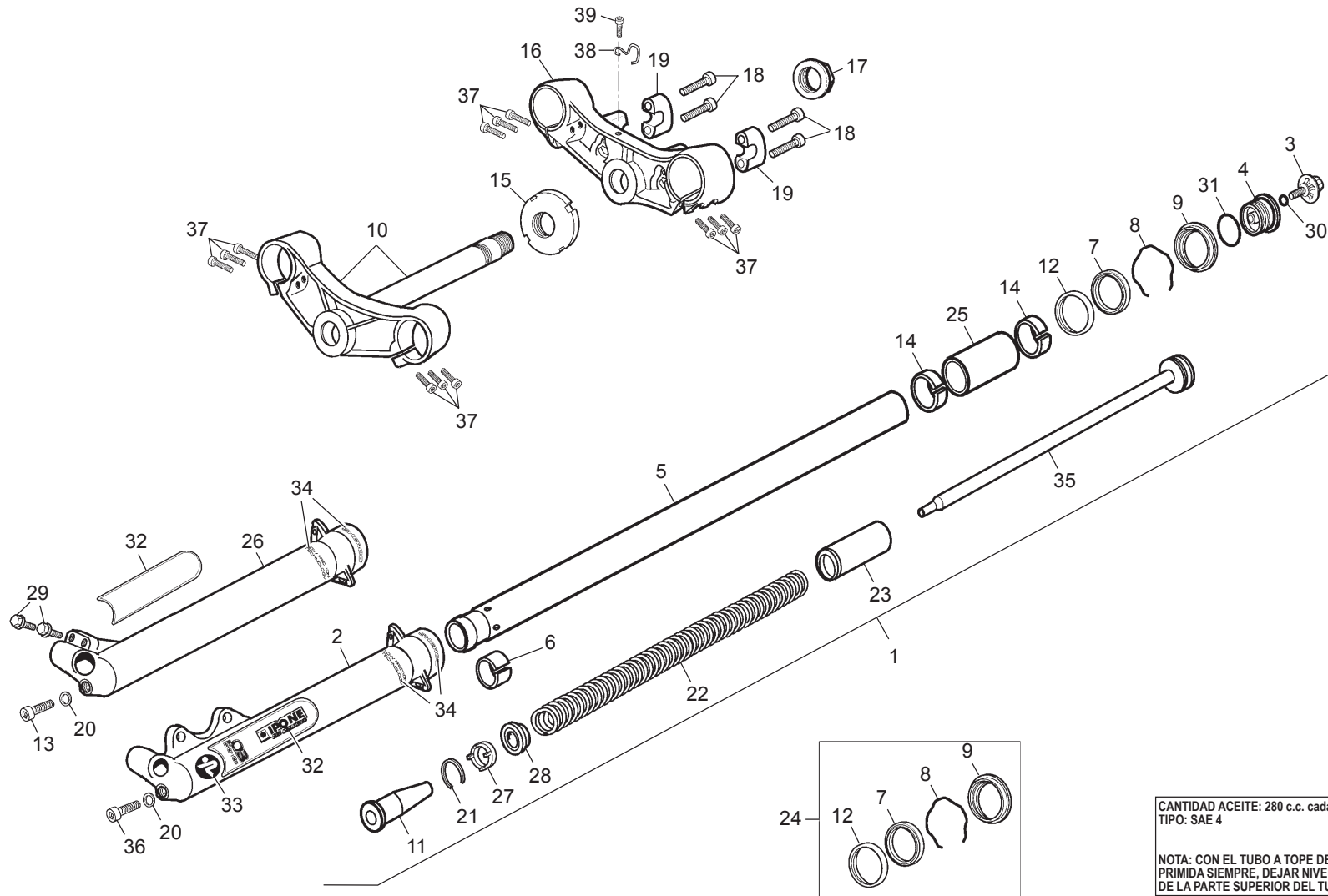

CANTIDAD ACEITE: 280 c.c. cada barra  
TIPO: SAE 4

NOTA: CON EL TUBO A TOPE DE SU CARRERA COM-  
PRIMIDA SIEMPRE, DEJAR NIVEL ACEITE A 130 mm.  
DE LA PARTE SUPERIOR DEL TUBO.

## Fourche / Fork / Horquilla

POS.	1.2	2.0	2.5	2.9	FRANÇAIS	ENGLISH	ESPAÑOL
1	C302	C302	C302	C302	FOURCHE CPL	FRONT FORK COMPLETE	SUSPENSIÓN DELANTERA COMPLETA
2	R104	R104	R104	R104	GROUPE JAMBE GAUCHE FOURCHE	FORK LEG (RIGHT)	BOTELLA IZQUIERDA
3	R222	R222	R222	R222	BOUCHON BLEU	AIR BLEEDER PLUG	TAPÓN AZUL
4	R098	R098	R098	R098	BOUCHON	FORK CAP	TAPÓN
5	R099	R099	R099	R099	TUBE FOURCHE G-D	FORK TUBE L-R	BARRA D-I
6	R134	R134	R134	R134	ENTRETOIRE DU	SPACER	CASQUILLO DU
7	R070	R070	R070	R070	JOINT SPIE DE FOURCHE	FORK OIL SEAL	RETEN.
8	R113	R113	R113	R113	CIRCLIP JOINT SPIE	CIRCLIP OIL SEAL	CIRCLIP RETÉN
9	R096	R096	R096	R096	PARE POUSSIERE FOURCHE	DUST SEAL	GUARDAPOLVO
10	R097	R097	R097	R097	GROUPE T DE FOURCHE INFERIEUR	BOTTOM PLATE	PLATINA INF. CON EJE
11	R223	R223	R223	R223	CONE	CONE	CONO
12	R131	R131	R131	R131	RONDELLE APUJE	WASHER FORK	ARANDELA APOYO
13	R224	R224	R224	R224	VIS CHC 10X30 FOURCHE	BOLT M10X30	TORNILLO M10X30 D.912
14	R133	R133	R133	R133	DU JAMBE 2000	SPACER	CASQUILLO DE BOTELLA
15	R110	R110	R110	R110	RONDELLE ECROU AXE DIRECTION	RING NUT	TUERCA DIRECCIÓN
16	R107	R107	R107	R107	T DE FOURCHE SUPERIEUR	UPPER PLATE	PLATÍNA SUPERIOR
17	R108	R108	R108	R108	ECROU SUPERIEUR	NUT	TUERCA SUPERIOR
18	R225	R225	R225	R225	VIS CHC M8X35	BOLT M8X35	TORN.ALLEN M8X35 D.912
19	R109	R109	R109	R109	BRIDE GUIDON SUPERIEURE	TOP BAR U-CLAMP	BRIDA SUPERIOR MANILLAR
20	R226	R226	R226	R226	RONDELLE 10X17X1,5 FURCHE 2001	WASHER 10X17X1,5	ARANDELA 10X17X1.5
21	R227	R227	R227	R227	ANEAU ELASTIQUE	NUT	ANILLO ELÁSTICO
22	R112	R112	R112	R112	RESSORT FOURCHE	SPRING	MUELLE
23	R111	R111	R111	R111	ENTRETOISE RESSORT FOURCHE	TOP BUSHING	TOPE MUELLE
24	R071	R071	R071	R071	GROUPE GARNITURE FOURCHE COMP.	FORK BUSHING AND SEAL KIT	KIT REPARACIÓN RETÉN.

## Fourche / Fork / Horquilla

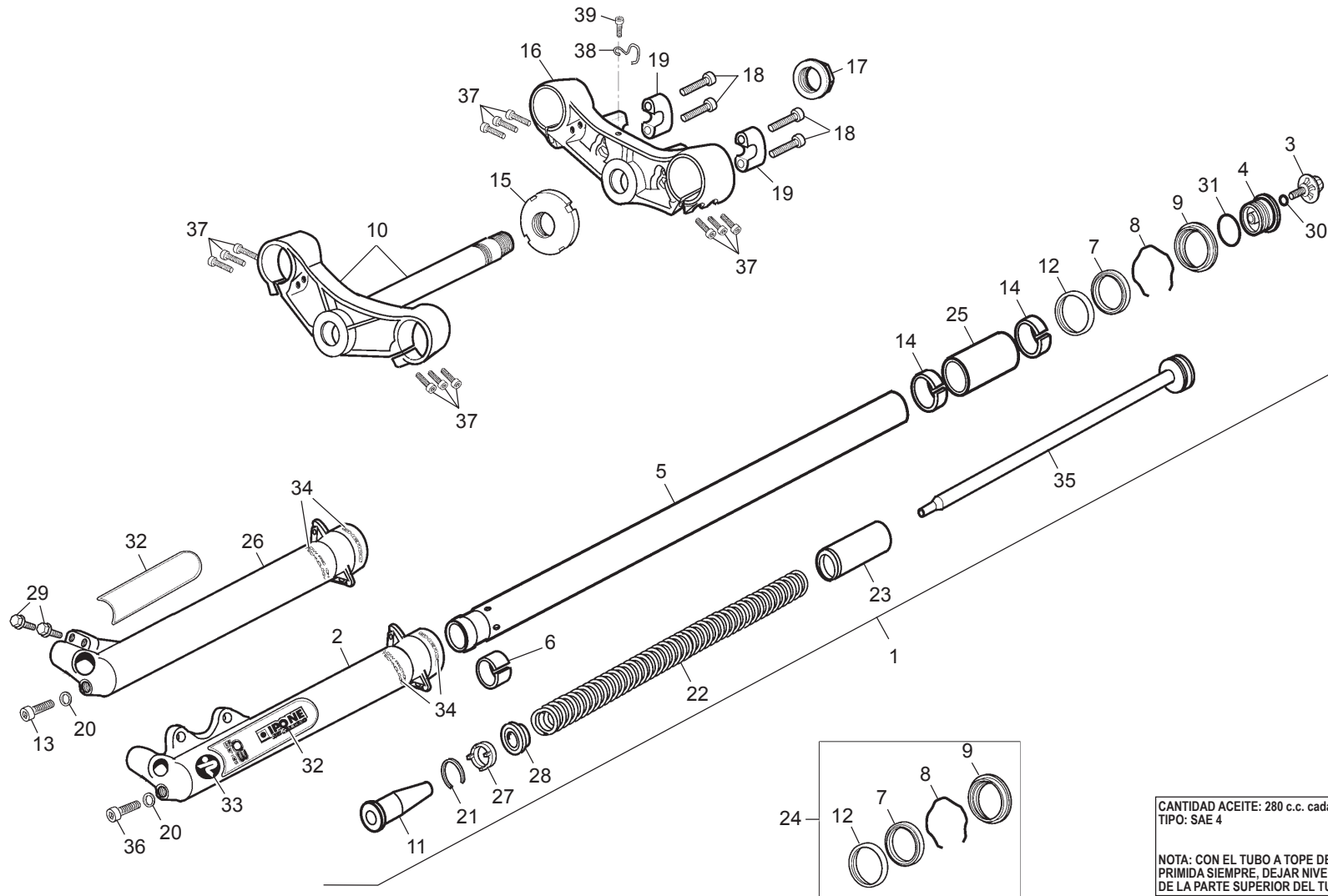

**Fourche / Fork / Horquilla**

POS.	1.2	2.0	2.5	2.9	FRANÇAIS	ENGLISH	ESPAÑOL
25	R132	R132	R132	R132	ENTRETOISE DU	SPACER	SEPARADOR DU
26	R105	R105	R105	R105	GROUPE JAMBE DROITE FOURCHE	FORK LEG (LEFT)	BOTELLA DERECHA
27	R228	R228	R228	R228	VALVE DE COMPRESSION	PLASTIC COMPRESSION VALVE	VÁLVULA DE COMPR.
28	R135	R135	R135	R135	RONDELLE APPUI RESSORT 2000	SPRING COLLAR	APOYO MUELLE
29	R229	R229	R229	R229	VIS M6X30 FOURCHE	BOLT M6X30	TORNILLO HEXAG. M6X30
30	R230	R230	R230	R230	TORIQUE FOURCHE	O.RING	TÓRICA CIERRE
31	R231	R231	R231	R231	TORIQUE BOUCHON BLEU	O.RING	TÓRICA TAPÓN
32	C631	C631	C631	C631	ADESIF IPONE PAIRE	IPONE BLUE STICKER PAIR	ADH. IPONE JUEGO AZUL
33	C186	C186	C186	C186	ADESIF LOGO PAIOLI RESINE	PAIOLI LOGO STICKER	PAIOLI REDONDO
34	C451	C451	C451	C451	AD SHERCO & LOW FRICTION	SHERCO & LOW FRICTION STICKER	AD SHERCO & LOW FRICTION
35	R106	R106	R106	R106	GROUPE CARTOUCHE	PLUNGER ASSEMBLY	CONJ. BOMBEO
36	C465	C465	C465	C465	VIS 10X30 FILETE INT.	SCREW	TORNILLO M10X30 CON ROSCA INT.
37	M255	M255	M255	M255	VIS CHC 6x25	SCREW CHC M6x25	TORNILLO M6x25
38	M273	M273	M273	M273	CAVALIER NORMA BSL1x8	CLIP FUEL OVERFLOW HOSE	BRIDA NORMA BSL1X8
39	M289	M289	M289	M289	ULS VIS BHC M6X12	SCREW M6X12	TORNILLO M6X12

**Kit homologation / Kit homologation / Kit homologación**

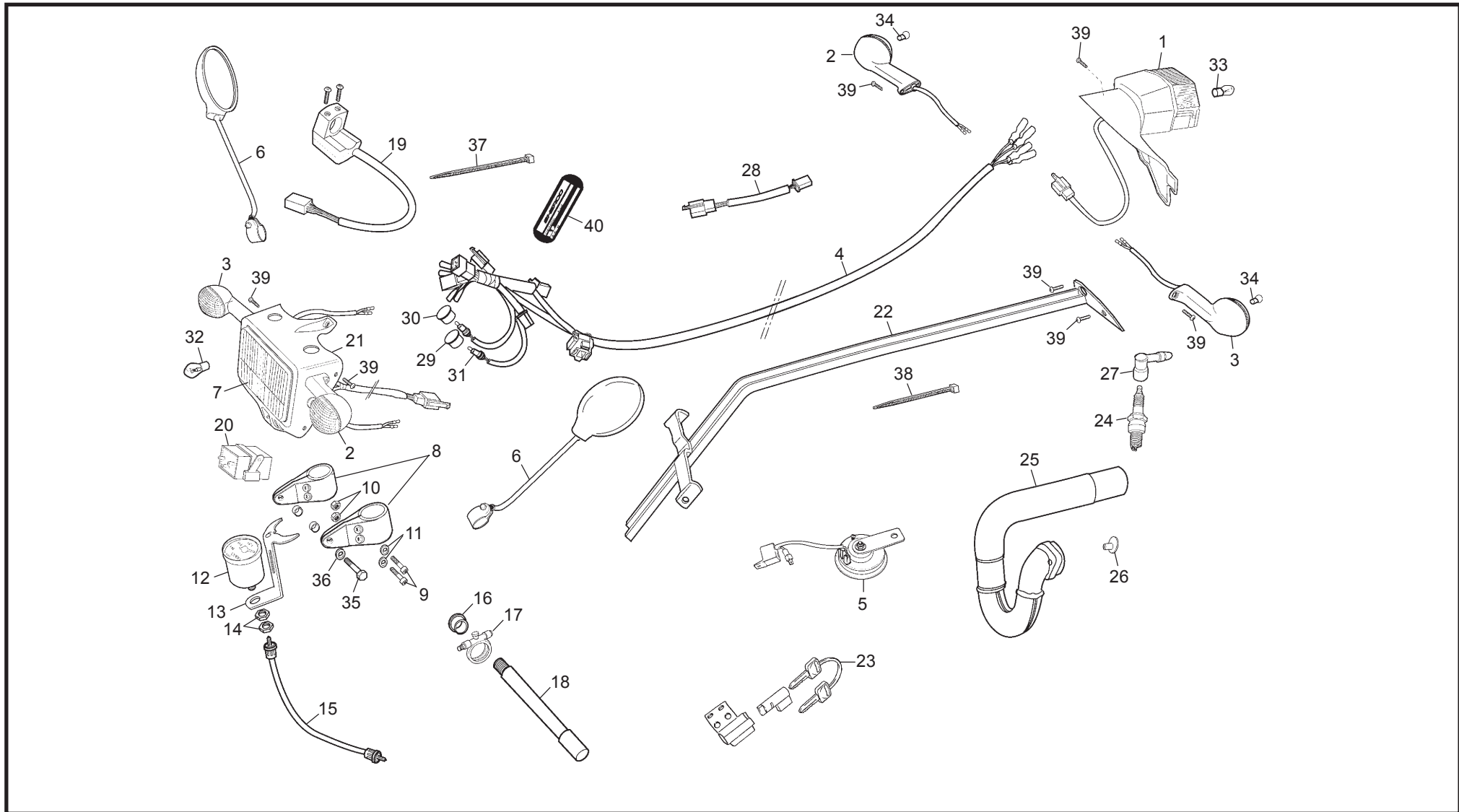

**Kit homologation / Kit homologation / Kit homologación**

POS.	1.2	2.0	2.5	2.9	FRANÇAIS	ENGLISH	ESPAÑOL
1	S231	.....	S231	S231	FEU ROUGE ARRIERE LUXAR	REAR LIGHT ASSY	PILOTO TRASERO COMPLETO
2	S233	.....	S233	S233	CLIGNO	INDICATOR	INTERMITENTE
3	S234	.....	S234	S234	CLIGNO	INDICATOR	INTERMITENTE
4	S252	.....	S252	S252	FAISSEAU ELECT CLIGNO CEE	LIGHT COIRE LOOM	INSTALACIÓN INTERMITENTES
5	C042	.....	C042	C042	AVERTISSEUR SONORE	HORN	CLAXON
6	S232	.....	S232	S232	RETROVISEUR	MIRROR	RETROVISOR
7	S230	.....	S230	S230	GROUPE FHARE AVANT CEV	FRONT LIGHT ASSY	FARO DELANTERO
8	S285	.....	S285	S285	SUPP. PLAQUE PHARE HOMOLOGATION	F/ LIGHT MOUNTING BRACKETS	SOPORTE FARO
9	M252	.....	M252	M252	VIS CHC M6X20	BOLTS	TORNILLO M6X20 DIN 912
10	M306	.....	M306	M306	ECROU NYLSTOP M6	NUTS	TUERCA M6
11	M322	.....	M322	M322	RONDELLE 6X14 CEE	WASHER	ARANDELA 6X14
12	R201	.....	R201	R201	COMPTEUR DE VITESSE	SPEEDOMETER ASSEMBLY	CUENTA KILÓMETROS
13	S287	.....	S287	S287	SUPPORT COMPTEUR FOURCHE	BRACKET	SOPORTE CUENTA Km.
14	R202	.....	R202	R202	ECROU SPECIAL COMPTEUR	NUT (LOCK)	TUERCA
15	R203	.....	R203	R203	CABLE COMPTEUR DE VITESSE	SPEEDOMETER CABLE	CABLE CUENTA Km.
16	R199	.....	R199	R199	RUBAN ADESIF SHERCO	SPACER	CASQUILLO REENVÍO
17	R200	.....	R200	R200	ENTRAINEUR DE COMPTEUR	SPEEDOMETER DRIVE	REENVIÓ
18	R209	.....	R209	R209	AXEA ROUE SPECIAL COMPTEUR	FRONT WHEEL AXLE	EJE ESPECIAL
19	S288	.....	S288	S288	FAISS. ELCTR. + CONMUTATEUR CLIGNO	ELECTRIC CABLE HOMOLOGATION	CONMUTADOR DE INTERMITENCIAS
20	S289	.....	S289	S289	CENTRAL CLIGNO HOMOLOGATION	INDICATOR LIGHT CENTRAL	CENTRAL INTERMITENCIAS
21	S251	.....	S251	S251	PLAQUE FHARE	FRONT LIGHT COVER	PLACA FARO
22	C306	.....	C306	C306	SUPPORT FEU HOMOLOGATION	SUPPORT HOMOLOGATION LIGHT	SOPORTE PILOTO TRASERO HOMOL.
23	C398	.....	C398	C398	ANTIVOL	BOLT	ANTIRROBO
24	C396	.....	C396	C396	BOUGIE ANTIPARASITE HOMOL	REISSTOR SPARK PLUG	BUJÍA ANTIPARASITARIA R

**Kit homologation / Kit homologation / Kit homologación**

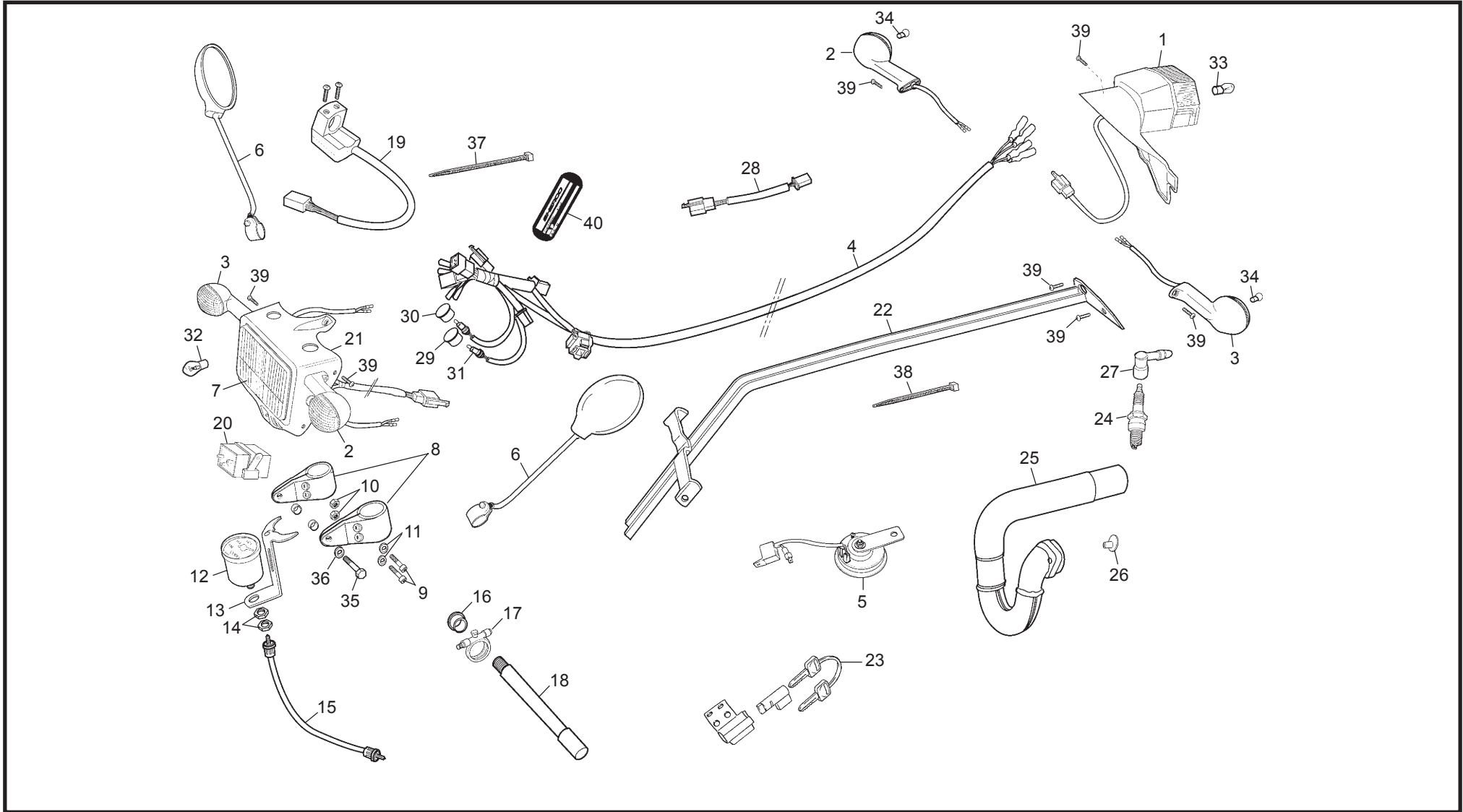

## Kit homologation / Kit homologation / Kit homologación

POS.	1.2	2.0	2.5	2.9	FRANÇAIS	ENGLISH	ESPAÑOL
25	C399	.....	C311	C311	TUBE ECHAPEMENT HOMOL	EXHAUST PIPE HOMOLOGATION	TUBO ESCAPE CON OBTURADOR
26	C397	.....	C397	C397	REDUCTION CARBU HOMOL	CARBURETOR RESTRICTOR	REDUCCIÓN CARBURADOR
27	C334	.....	C334	C334	ANTIPARASITE HOMOLOGUE	PLUG COVER HOMOLOGATION	PIPA HOMOLOGACIÓN R
28	C395	.....	C395	C395	RALLONGE FAISSEAU FEU ARR HOMOL	EXTENSION CABLE	ALARGO INSTALACIÓN PILOTO TRASERO
29	C400	.....	C400	C400	TEMOIN VERD	TEST LIGHT GREEN	TESTIGO VERDE
30	C401	.....	C401	C401	TEMOIN BLEU	TEST LIGHT BLUE	TESTIGO AZUL
31	C402	.....	C402	C402	AMPOULE TEMOIN 13W 12V	BULB TEST	BOMBILLA TESTIGOS 13W 12V
32	C403	.....	C403	C403	AMPOULE FARE 35/35W 12V	BULB FRONT LIGHT	BOMBILLA FARO 35/35W 12V
33	C404	.....	C404	C404	AMPOULE PILOTE ARR 21/5W 12V	BULB BACK LIGHT	BOMBILLA PILOTO TRAS 21/5W 12V
34	C405	.....	C405	C405	AMPOULE CLIGNO 10W/12V	BULB IND LIGHT	BOMBILLA INTERMITENTES 10W/12V
35	M284	.....	M284	M284	VIS BHC M6X25	SCREW M6X25	TORNILLO M6X25 ULS
36	M321	.....	M321	M321	RONDELLE M6X18	WASHER 6X18	ARANDELA M6X18
37	M330	.....	M330	M330	COLLIER 178X4.8	BRACKET 178X4.8	ABRAZADERA 178X4.8
38	M331	.....	M331	M331	COLLIER 100X2.5	BRACKET 100X2,5	ABRAZADERA 100X2.5
39	M335	.....	M335	M335	VIS TOLE 3.9X16	SCREW 3.9X6	TORNILLO ROSCA CHAPA 3.9X16
40	C904	.....	C904	C904	PLAQUE CONSTRUCTEUR	CONSTRUCTOR STICKER	PLACA CONSTRUCTOR

**Moteur / Engine / Motor**

EVOLUCIÓN DOS A PARTIR N° CHASIS 003530		
Pos.	Ref.	Ref. EVO.2
3	M004	M353
18	M025	M352
19	M026	M351

EVOLUCIÓN TRES A PARTIR N° CHASIS 005280	
Pos.	Ref.
3	M364
18	M363

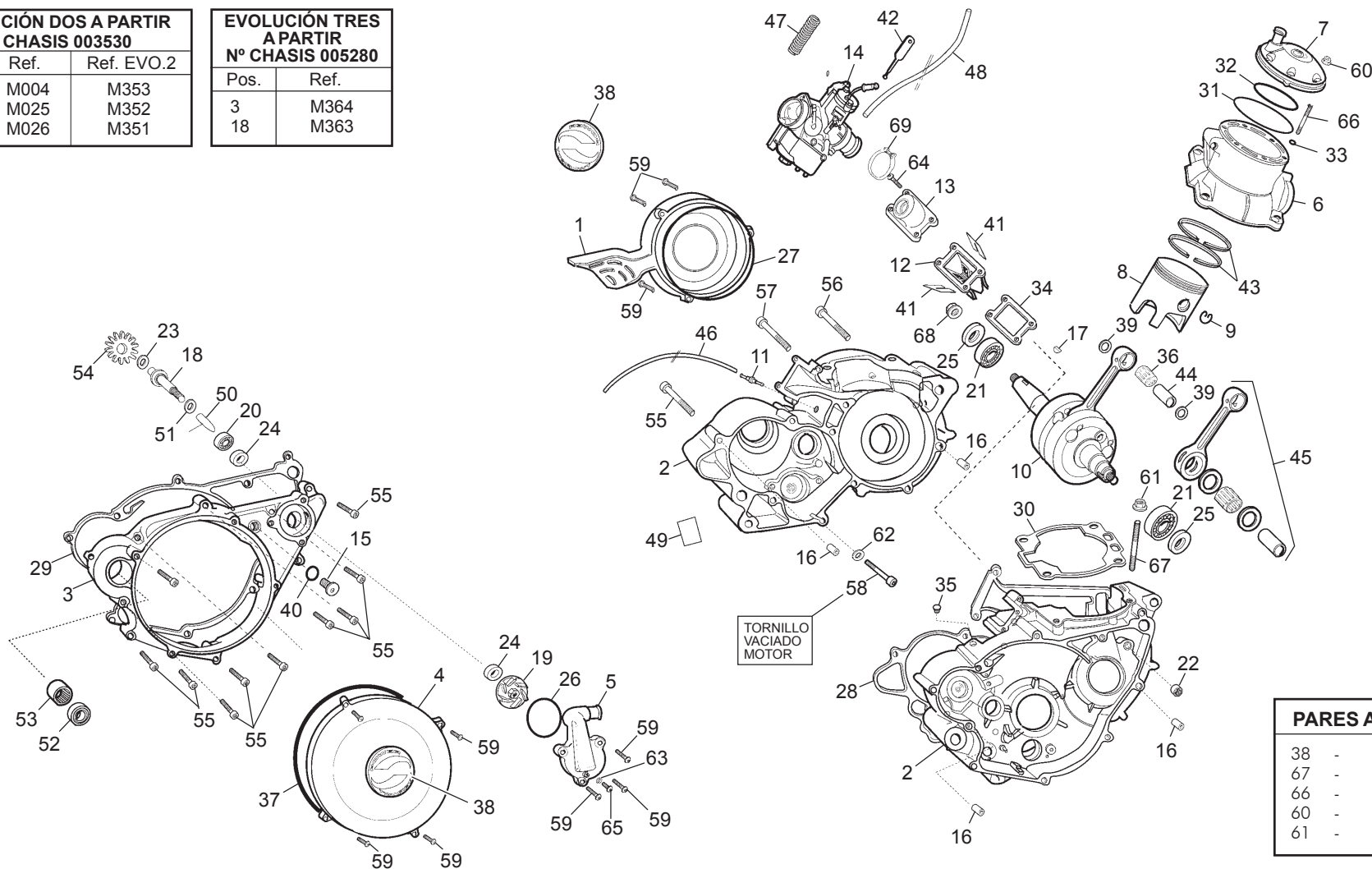

**Moteur / Engine / Motor**

POS.	1.2	2.0	2.5	2.9	FRANÇAIS	ENGLISH	ESPAÑOL
1	M381	M381	M381	M381	CARTER ALLUMAGE	IGNITION COVER	TAPA ENCENDIDO
2	M210	M210	M002	M002	GROUPE CARTERS CENTRAUX	CRANCKCASES SET	CARTERS CENTRALES
3	M382	M382	M382	M382	COVER CARTER LATERAL DROIT	ENGINE SIDE CASE	CARTER LATERAL DERECHO
4	M383	M383	M383	M383	COUVERCLE EMBRAYAGE	CLUTCH COVER	TAPETA EMBRAGUE
5	M384	M384	M384	M384	COUVERCLE POMPE EAU	WATER PUMP COVER	TAPA BOMBA AGUA
6	M214	M215	M007	M246	CYLINDRE	CYLINDER	CILINDRO
7	M388	M387	M386	M385	CULASSE	CYLINDER HEAD	CULATA
8	M212	M213	M009	M245	PISTON COMPLET	PISTON COMPLETE	PISTÓN + BULÓN + AROS + CIRCLIPS
9	R218	R218	M013	M013	CIRCLIPS PISTON	PISTON CIRCLIP	SERCLIP PISTÓN
10	M211	M211	M014	M014	VILEBREQUIN COMPLET	CRANK SHAFT ASSY	CIGÜEÑAL COMPLETO
11	M016	M016	M016	M016	RENIFLAR CARTER CENTRAL	CRANKCASE BREATHER	TUBO DEPRESOR CARTERS
12	M018	M018	M018	M018	BOITE A CLAPETS	REEDS CASE	CAJA DE LAMINAS COMPLETA
13	M019	M019	M019	M019	PIPE ADMISSION	INTAKE MANIFOLD	TOBERA ADMISIÓN
14	M020	M020	M020	M020	CARBURATEUR COMPLET	CARBURETOR COMPLETE	CARBURADOR COMPLETO
15	M021	M021	M021	M021	BOUCHON REMPLISSAGE HUILE	TRANSMISSION OIL FILLER CAP	TAPÓN LLENADO ACEITE CARTER
16	M022	M022	M022	M022	CARTER DOUILLE CENTRAGE CARTER	DOWEL PIN	CASQUILLO CENTRADOR
17	M023	M023	M023	M023	CLAVETTE DEMI LUNE VIL	WOODRUFF KEY	CHAVETA ENCENDIDO
18	M363	M363	M363	M363	AXE POMPE A EAU	WATERPUMP SHAFT	EJE BOMBA AGUA
19	M351	M351	M351	M351	TURBINE DE POMPE A EAU	WATERPUMP IMPELLER	TURBINA BOMBA AGUA
20	M027	M027	M027	M027	ROULEMENT BILLE POMPE EAU 608.2RS	WATERPUMP BEARING	COJINETE BOMBA AGUA 608 2RS
21	M218	M218	M028	M028	ROULEMENT BILLE VILO 6206.C3	CRANCKSHAFT BEARING	COJINETE CIGÜEÑAL 6206 C3
22	M029	M029	M029	M029	ROULEMENT AIGUILLE POMPE EAU	WATERPUMP NEEDLE BEARING	COJIN. AGUJAS BOMBA AGUA ARANDE-
23	M030	M030	M030	M030	RONDELLE BUTEE POMPE A EAU 8x16x1	WATERPUMP BUSHING 8X1 6X1	LA BOMBA AGUA 8X16X1
24	M031	M031	M031	M031	JOINT LEVRE POMPE A EAU 8x20x5DL	WATERPUMP SEAL	RETÉN BOMBA AGUA

Moteur / Engine / Motor

EVOLUCIÓN DOS A PARTIR N° CHASIS 003530		
Pos.	Ref.	Ref. EVO.2
3	M004	M353
18	M025	M352
19	M026	M351

EVOLUCIÓN TRES A PARTIR N° CHASIS 005280	
Pos.	Ref.
3	M364
18	M363

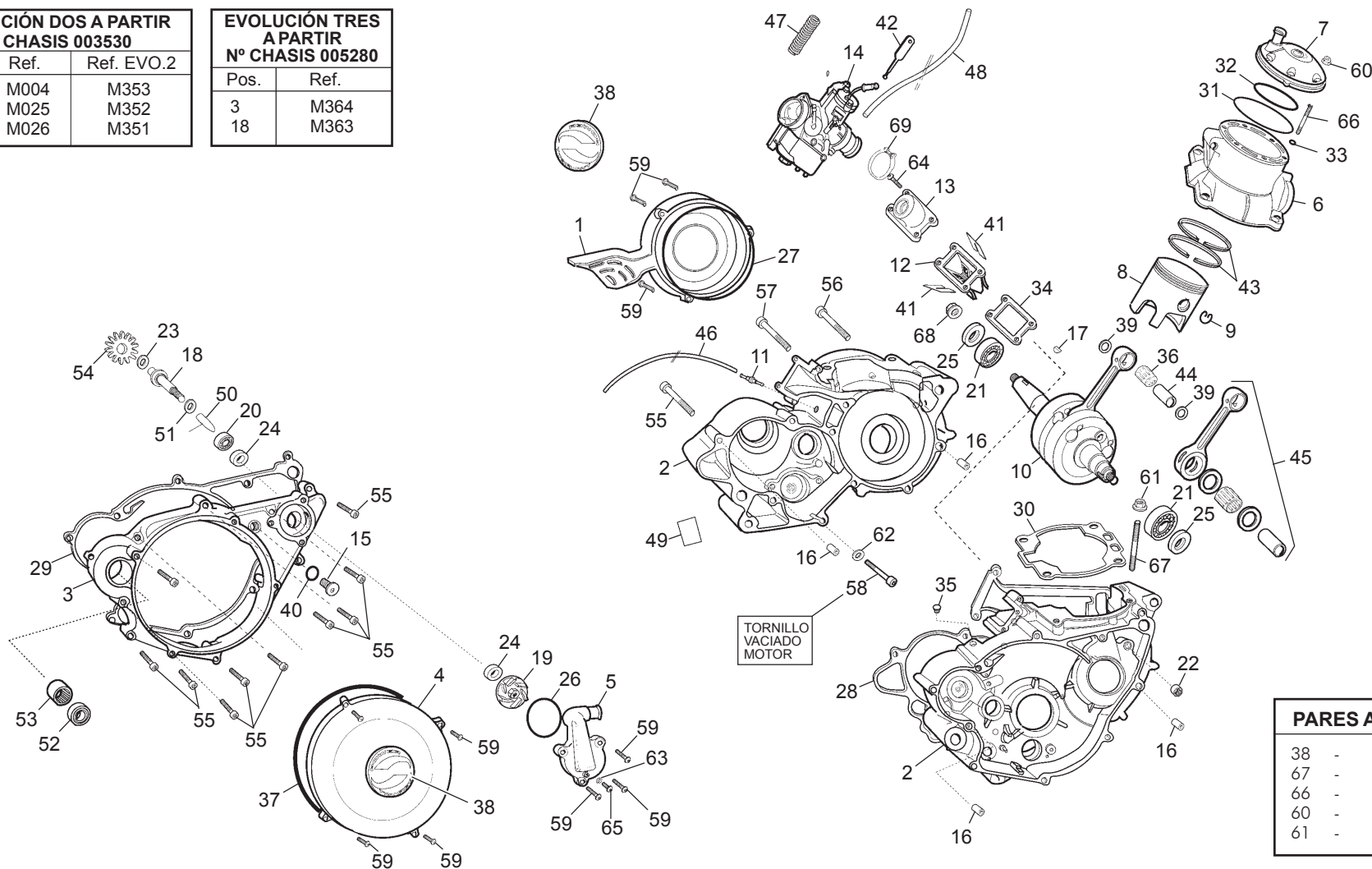

PARES APRIETE	
38	- 100 Nm.
67	- 22 Nm.
66	- 10 Nm.
60	- 10 Nm.
61	- 22 Nm.

**Moteur / Engine / Motor**

POS.	1.2	2.0	2.5	2.9	FRANÇAIS	ENGLISH	ESPAÑOL
25	M219	M219	M032	M032	JOINT LEVRE VILO 24x40x7DL	CRANCKSHAFT SEAL	RETÉN CIGÜEÑAL
26	M033	M033	M033	M033	JOINT TORIQUE COUVERCLE POMPE	O-RING WATERPUMP COVER	JUNTA TÓRICA TAPA BOMBA AGUA
27	M034	M034	M034	M034	JOINT TORIQUE COUVERCLE ALLUMAGE	O-RING IGNITION COVER	JUNTA TÓRICA TAPA ENCENDIDO
28	M220	M220	M035	M035	JOINT CARTER CENTRAL	CRANKCASE GASKET	JUNTA CARTER CENTRAL
29	M036	M036	M036	M036	JOINT CARTER LATERAL	ENGINE SIDE CASE GASKET	JUNTA CARTER LATERAL
30	M221	M221	M037	M037	JOINT EMBASE CYLINDRE	CYLINDER GASKET	JUNTA CILINDRO
31	M222	M222	M222	M038	JOINT TORIQUE CULASSE VITON	CYLINDER HEAD O-RING	JUNTA TÓRICA CULATA EXTERIOR
32	M223	M223	M223	M039	JOINT TORIQUE CULASSE VITON	CYLINDER HEAD O-RING	JUNTA TÓRICA CULATA INTERIOR
33	M040	M040	M040	M040	JOINT TORIQUE CYLINDRE 5,7x1,9	CYLINDER HEAD O-RING BOLT 5,7X1,9	JUNTA TÓRICA ESPAR. CULATA 5,7X1,9
34	M041	M041	M041	M041	JOINT BOITE CLAPET	REEDCASE GASKET	JUNTA CAJA LAMINAS
35	M042	M042	M042	M042	RIVET CARTER CENTRAL	CRANKCASE RIVET	REMACHE CARTER CENTRAL
36	M241	M241	M043	M248	CAGE AIGUILLE PISTON KBK 18x22x24	PISTON NEEDLE BEARING	COJIN. GUJAS PISTÓN KBK 18X22X24
37	M045	M045	M045	M045	JOINT TORIQUE 155x2	O-RING 155x2	JUNTA TÓRICA 155X2 TAPA EMBRAGUE
38	M395	M394	M393	M389	ADESIF RESINE	THUMBS ENGINE STICKER	ADHESIVO CARTER
39	.....	M354	.....	.....	RONDELLE SPECIAL PISTON	PISTON WRIST PIN SHIMS	ARANDELA ESPECIAL PISTÓN
40	M162	M162	M162	M162	TORIQUE 10x2.5 BOUCHON HUILE	O-RING	JUNTA TÓRICA TAPÓN ACEITE
41	R022	R022	R022	R022	CLAPET RECHANGE	REED VALVES	JUEGO LAMINAS
42	M015	M015	M015	M015	LEVIER STARTER	CHOKE LEVER TAG	TIRADOR STARTER
43	R213	R214	R012	R215	SEGMENT RECTANGULAIRE	STANDARD SIZE PISTON RINGS	ARO RECTANGULAR
44	R219	R220	R013	R221	AXE DE PISTON	PISTON PIN	BULON PISTÓN
45	R212	R212	R021	R021	KIT BIELLE	CRANCKSHAFT REPAIR KIT	KIT BIELA
46	M017	M017	M017	M017	DURITE RENIFLAR 3X5	CRANKCASE BREATHER PIPE	TUBO DEPRESOR 3X5
47	M044	M044	M044	M044	RESSORT CARBURATEUR	CARBURETOR SPRING	MUELLE CARBURADOR
48	M012	M012	M012	M012	DURITE ESSENCE CARBURATUER	RUBBER FUEL LINE	TUBO GASOLINA CARBURADOR

Moteur / Engine / Motor

EVOLUCIÓN DOS A PARTIR N° CHASIS 003530		
Pos.	Ref.	Ref. EVO.2
3	M004	M353
18	M025	M352
19	M026	M351

EVOLUCIÓN TRES A PARTIR N° CHASIS 005280	
Pos.	Ref.
3	M364
18	M363

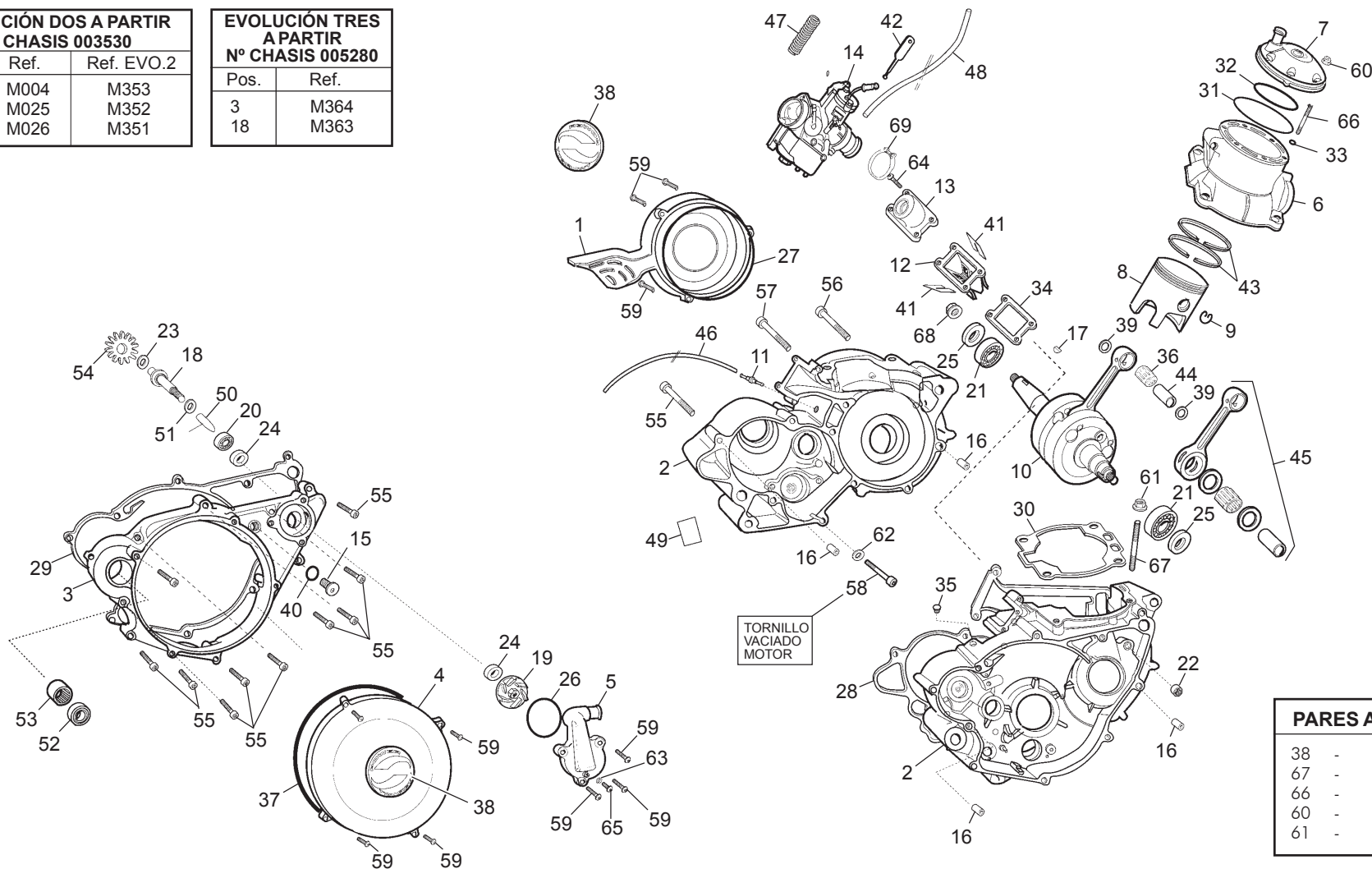

PARES APRIETE	
38	- 100 Nm.
67	- 22 Nm.
66	- 10 Nm.
60	- 10 Nm.
61	- 22 Nm.

**Moteur / Engine / Motor**

POS.	1.2	2.0	2.5	2.9	FRANÇAIS	ENGLISH	ESPAÑOL
49	M079	M079	M079	M079	ADESIF OIL OUT	OIL DRAIN STICKER	ADHESIVO OIL OUT
50	R232	R232	R232	R232	CAPUCHON FILETAGE AXE POMPE EAU	WATER PUMP SHAFT PIN	ÚTIL PROTECCIÓN ROSCA
51	M049	M049	M049	M049	RONDELLE BUTEE POMPE A EAU8X16X0.5	WATER PUMP BUSHING 8X16X0.5	ARANDELA 8X16X0.5
52	M170	M170	M170	M170	JOINT DOUBLE LEVRES 17x28x5 DL	OIL SEAL 17x28x5 DL	RETÉN DOBLE LABIO 17X28X5 DL
53	M077	M077	M077	M077	DOUILLE AGUILLE HK1712 B	NEEDLE ROLLER BEARING HK1712 B	JAULA AGUJAS HK1712 B
54	M364	M364	M364	M364	PIGNON POMPE EAU	WATER PUMP PINON	PIÑÓN BOMBA AGUA
55	M253	M253	M253	M253	VIS CHC 6x30	SCREW CHC 6x30	TORNILLO M6X30 DIN 912
56	M254	M254	M254	M254	VIS CHC 6x55	SCREW CHC 6x55	TORNILLO M6X55 DIN 912
57	M256	M256	M256	M256	VIS CHC 6x45	SCREW CHC 6x45	TORNILLO M6X45 DIN 912
58	M257	M257	M257	M257	VIS CHC 6x60	SCREW CHC 6x60	TORNILLO M6X60 DIN 912
59	M258	M258	M258	M258	VIS BHC 5x16	SCREW CHC 5x16	TORNILLO M5X16 UL5
60	M271	M271	M271	M271	ECROU EMBASE x6	COLLAR HEX NUT M6	TUERCA M6 CON VALONA DIN 6923 B
61	M272	M272	M272	M272	ECROU EMBASE x8	COLLAR HEX NUT M8	TUERCA M8 CON VALONA DIN 6923 B
62	M276	M276	M276	M276	RONDELLE ALU M 6	METAL GASKET X6	ARANDELA 6 ALUMINIO
63	M277	M277	M277	M277	RONDELLE ALU M 5	METAL GASKET X5	ARANDELA 5 ALUMINIO
64	M279	M279	M279	M279	VIS BHC 6x20	SCREW BHC 6x20	TORNILLO M6X20 UL5
65	C358	C358	C358	C358	VIS CHC 4X6	SCREW CHC 4X6	TORNILLO 4X6 DIN 912
66	M290	M290	M290	M290	GOIJON DE CULASSE 6x38	STUD CYLINDER HEAD 6x38	ESPÁRRAGO CULATA 6X38
67	M291	M291	M291	M291	GOIJON DE CILYNDRE 8x46	STUD CYLINDER 8x46	ESPARRAGO CILINDRO 8X46
68	M295	M295	M295	M295	ECROU 14x125	HEX NUT M14x125	TUERCA 14X125
69	C110	C110	C110	C110	COLLIER NORMA 32/50	HOSE CLAMP	ABRAZADERA NORMA 32/50

**Boite auitesses / Gear box / Caja de cambios**

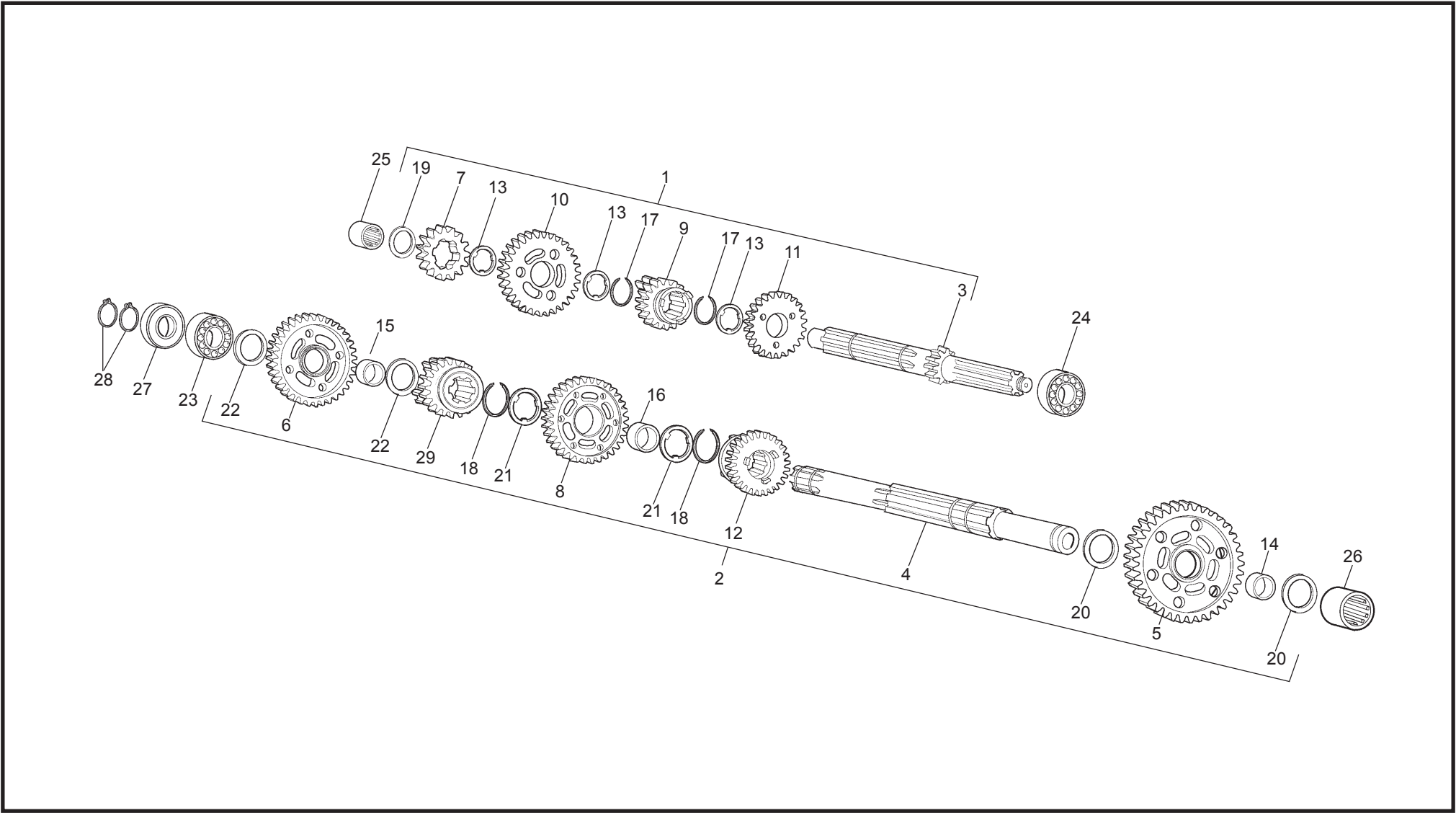

## Boite auitesses / Gear box / Caja de cambios

POS.	1.2	2.0	2.5	2.9	FRANÇAIS	ENGLISH	ESPAÑOL
1	M050	M050	M365	M365	ENSEMBLE ARBRE PRIMAIRE	GROUP PRIMARY SHAFT WITH PINION	CJTO. EJE PRIM. CAMBIO
2	M051	M051	M366	M366	ENSEMBLE ARBRE SECONDAIRE	GROUP SECONDARY SHAFT WITH PINION	CJTO. EJE SECUN. CAMBIO
3	M053	M053	M374	M374	ARBRE PRIMAIRE ET PIGNON DE 1ERE	CLUTCH SHAFT	EJE PRIMARIO
4	M054	M054	M054	M054	ARBRE SECONDAIRE	MAINSHAFT	EJE SECUNDARIO
5	M055	M055	M367	M367	ROUE LIBRE DE 1ERE	FREE PINION 1ER	CORONA DE 1°
6	M056	M056	M056	M056	ROUE LIBRE DE 2EME	FREE PINION 2EME	CORONA DE 2°
7	M057	M057	M057	M057	PIGNON FIXE DE 2EME	GEAR PINION 2EME	PIÑÓN DE 2°
8	M058	M058	M058	M058	ROUE LIBRE DE 3EME	FREE PINION 3EME	CORONA DE 3°
9	M059	M059	M059	M059	PIGNON BALADEUR DE 3EME	GEAR PINION 3EME	PIÑÓN DESPLAZABLE 3°
10	M061	M061	M061	M061	ROUE LIBRE DE 5EME	FREE PINION 5EME	CORONA LIBRE DE 5°
11	M062	M062	M062	M062	LIBRE DE 4EME	GEAR PINION 4EME	PIÑÓN DE 4°
12	M063	M063	M063	M063	ROUE BALADEUSE DE 4EME	FREE PINION 4EME	CORONA DESPLAZABLE DE 4°
13	M064	M064	M064	M064	RONDELLE CRENEAUX 20x24x1	GEAR WASHER	ARANDELA ESTRIADA
14	M065	M065	M065	M065	DOUILLE ANTI FRICTION 1ERE	BUSHING 1ERE	CASQUILLO ANTI-FRICCIÓN 1°
15	M066	M066	M066	M066	DOUILLE ANTI FRICTION 2EME	BUSHING 2EME	CASQUILLO ANTI-FRICCIÓN 2°
16	M067	M067	M067	M067	DOUILLE ANTI FRICTION 3EME	BUSHING 3EME	CASQUILLO ANTI-FRICCIÓN 3°
17	M068	M068	M068	M068	SEGMENT ARRET WR20	RETAINING WR 20	SEEGER WR 20
18	M069	M069	M069	M069	SEGMENT ARRET WR22	RETAINING WR 22	SEEGER WR 22
19	M070	M070	M070	M070	RONDELLE INA ARBRE PRIMAIRE 27,8X15X1	THRUST WASHER 28,7X15X1	ARANDELA INA EJE PRIMARIO 27,8X15X1
20	M071	M071	M071	M071	ARBRE SECONDAIRE 17x27x1	MAINSHAFT WASHER	ARANDELA EJE SECUNDARIO
21	M072	M072	M072	M072	RONDELLE CRENEAU ARBRE	WASHER	ARANDELA ESTRIADA EJE SECUNDARIO
22	M073	M073	M073	M073	RONDELLE ARBRE SECONDAIRE 20x27x1	MAINSHAFT WASHER	ARANDELA EJE SECUNDARIO
23	M074	M074	M074	M074	ROULEMENT 20x47x14	BEARING 20x47x14	COJINETE 20X47X14 6204 C3
24	M075	M075	M075	M075	ROULEMENT 20x47x14 RSR	BEARING 20x47x14RSR	COJINETE 20X47X14 6204 RS

**Boite auitesses / Gear box / Caja de cambios**

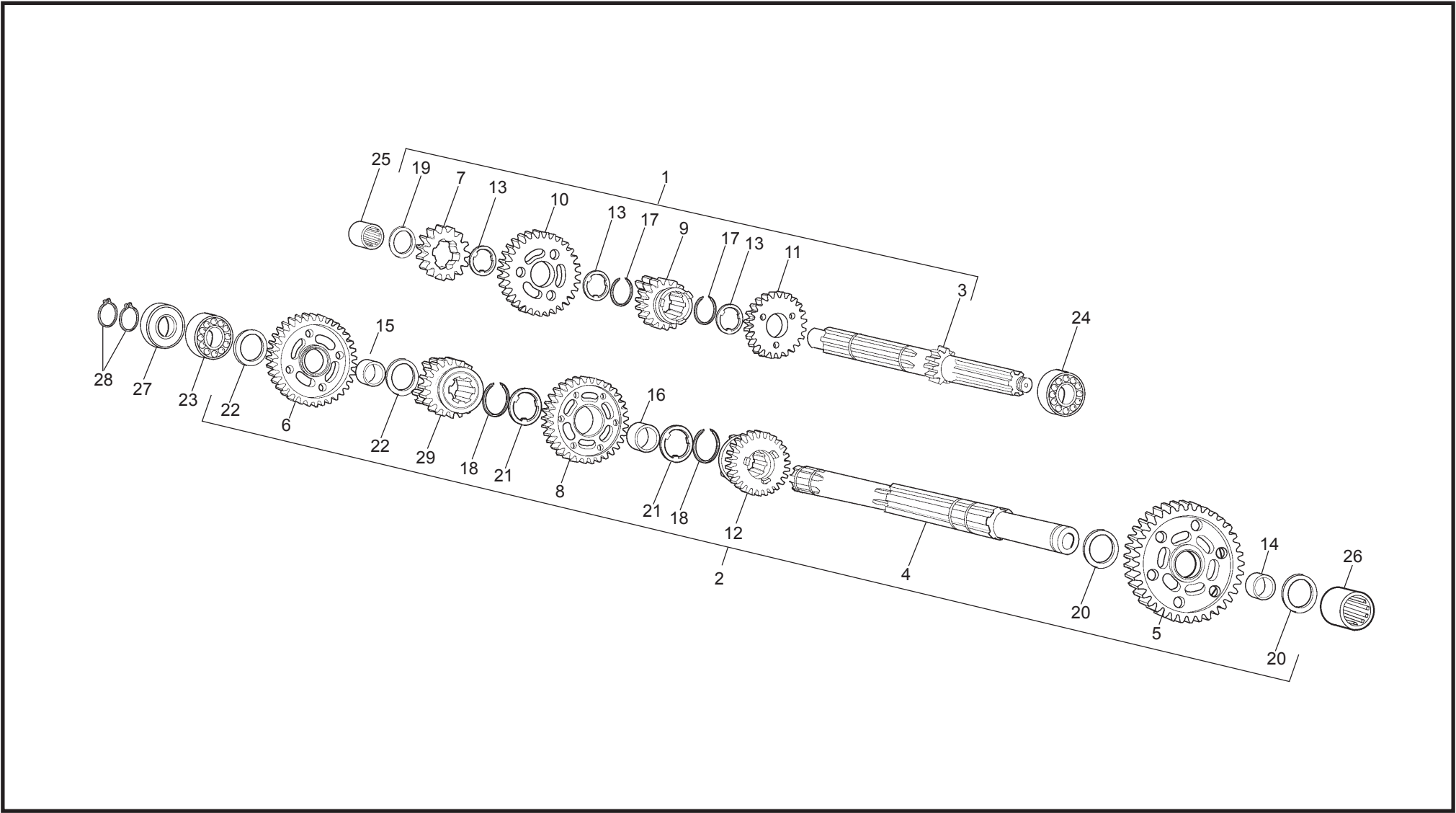

**Boite auitesses / Gear box / Caja de cambios**

POS.	1.2	2.0	2.5	2.9	FRANÇAIS	ENGLISH	ESPAÑOL
25	M076	M076	M076	M076	DOUILLE AIGUILLE 15x21x12	NEEDLE BEARING 15x21x12	CASQUILLO DE AGUJAS 15X21X12
26	M077	M077	M077	M077	DOUILLE AIGUILLE HK1712B	NEEDLE BEARING 17x23x12	CASQUILLO DE AGUJAS HK1712B
27	M078	M078	M078	M078	DOUBLE LEVRE20x30x7	OIL SEAL 20x30x7 JOINT	RETÉN DOBLE LABIO 20X30X7
28	M350	M350	M350	M350	ARRET WR20 SORTIE BOITE	SNAP RING WR20	SEGMENT. ARRET WR20
29	M060	M060	M060	M060	PIGNON LIBRE DE 5EME	GEAR PINION 5EME	PIÑÓN DE 5ª

**Embrayage / Clutch / Embrague**

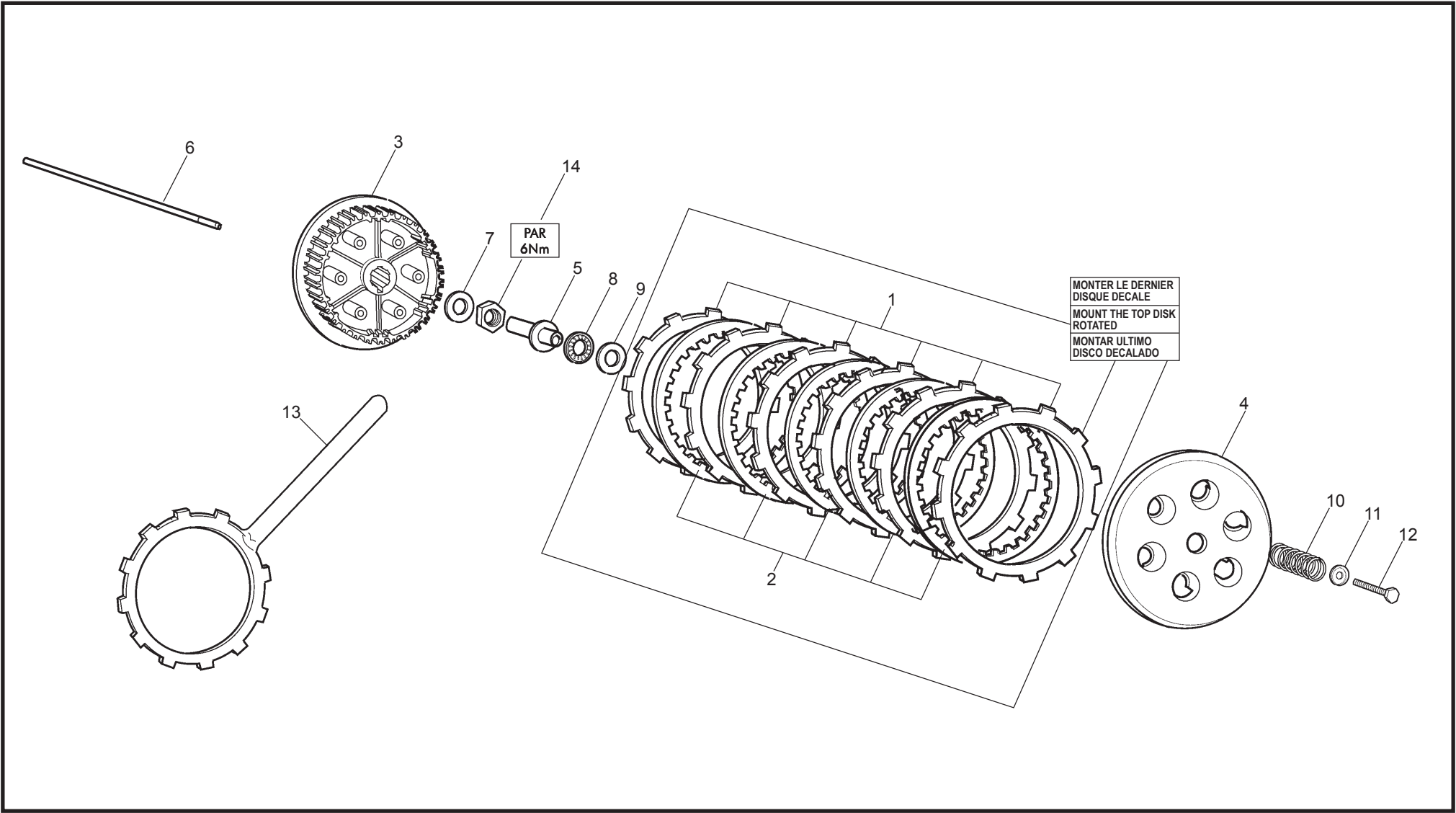

**Embrayage / Clutch / Embrague**

POS.	1.2	2.0	2.5	2.9	FRANÇAIS	ENGLISH	ESPAÑOL
1	M080	M080	M080	M080	DISQUE GARNI	FRICITION CLUTCH DISK	DISCO EMBRAGUE FORRADO
2	M081	M081	M081	M081	DISQUE LISE	METAL CLUTCH DISK	DISCO EMBRAGUE METÁLICO
3	M083	M083	M083	M083	NOYAU	CLUTCH HUB	CUBO EMBRAGUE
4	M084	M084	M084	M084	PLATEAU	CLUTCH PRESSURE PLATE	PLATO EMBRAGUE
5	M085	M085	M085	M085	POUSSOIR AXIAL	CLUTCH ACTUATOR	PULSADOR AXIAL
6	M086	M086	M086	M086	TIGE DE POUSSEE	CLUTCH ACTIVATING ROD	VARILLA EMBRAGUE
7	M087	M087	M087	M087	RONDELLE BELLEVILLE 16,3x31,5x1,5	BELLEVILLE WASHER 16,3X31,5X1,5	ARANDELA FIJACIÓN 16,3X31,5X1,5
8	M090	M090	M090	M090	BUTEE AIGUILLE EMB AXK1226A	CLUTCH BEARING	CASQ. AGUJAS EMBRAGUE AXK1226A
9	M091	M091	M091	M091	RONDELLE BUTEE AS 12X26X1	THRUST WASHER 12X26X1	ARANDELA AS 12X26X1
10	M092	M092	M092	M092	RESSORT EMB	CLUTCH SPRING	MUELLE EMBRAGUE
11	M093	M093	M093	M093	RONDELLE EMB	CLUTCH SPRING WASHER	ARANDELA EMBRAGUE
12	M094	M094	M094	M094	VIS EMB	CLUTCH SPRING SCREW	TORNILLOS MUELLE EMBRAGUE
13	R037	R037	R037	R037	SPECIAL CLUTCH STRIP TOOL	CLUTCH HOLDING TOOL	ÚTIL EMBRAGUE
14	M293	M293	M293	M293	ECROU NOYAU EMB M16x125	HEX NUT CLUTCH M16x125	TUERCA CUBO EMBRAGUE M16X125

**Selection / Selector / Selector**

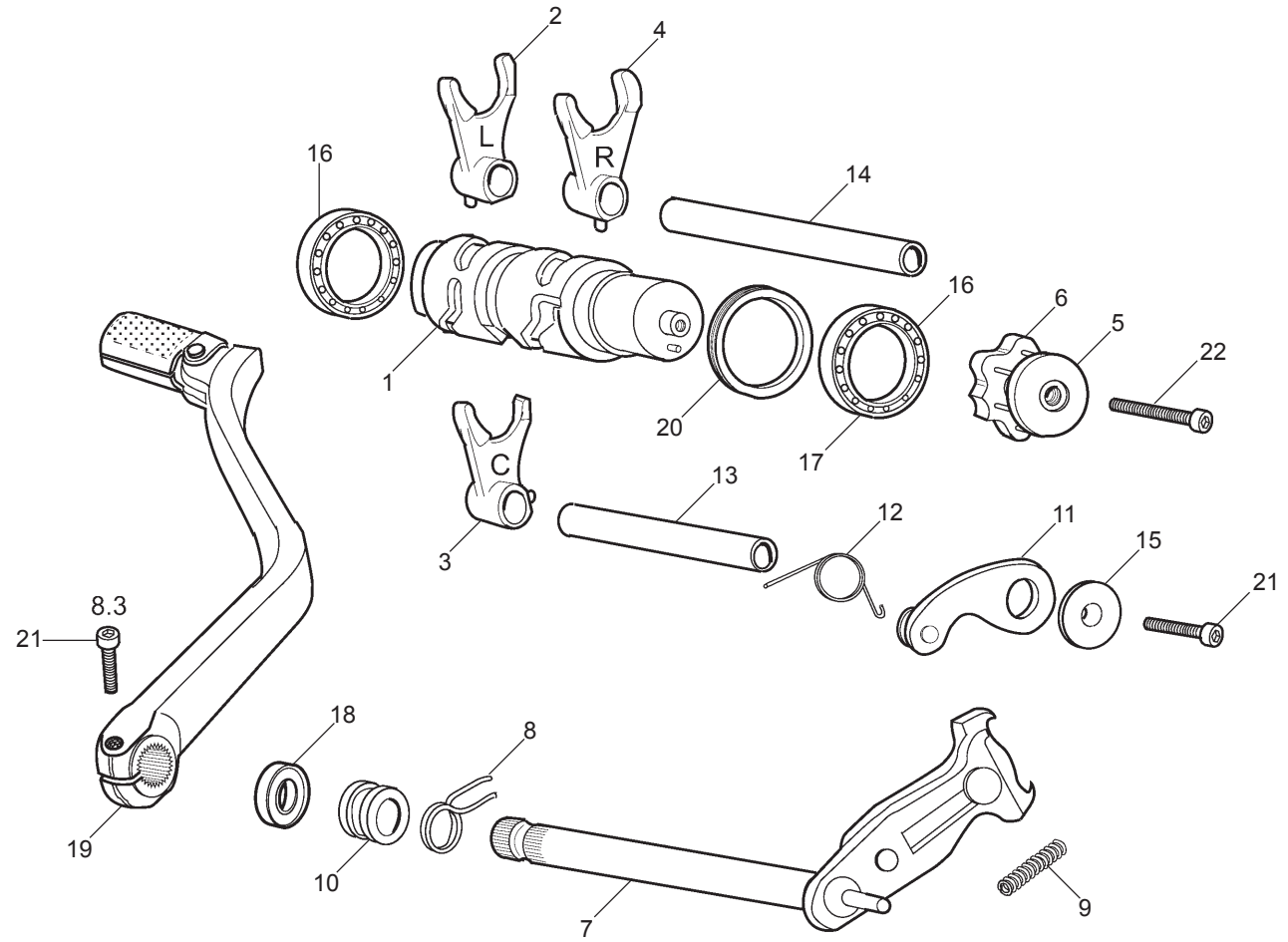

**Selection / Selector / Selector**

POS.	1.2	2.0	2.5	2.9	FRANÇAIS	ENGLISH	ESPAÑOL
1	M100	M100	M100	M100	TAMBOUR DE SELECTION	SELECTOR DRUM	DESMODROMICO SELECTOR
2	M102	M102	M102	M102	FOURCHETTE L	L FORK	HORQUILLA L
3	M103	M103	M103	M103	FOURCHETTE	C FORK	HORQUILLA C
4	M104	M104	M104	M104	FOURCHETTE R	R FORK	HORQUILLA R
5	M105	M105	M105	M105	ETOILE DE SELECTION CPL	INDEX SHIM	ESTRELLA SELECTOR
6	M106	M106	M106	M106	PION ETOILE INA NRA 3x19,8	SELECTOR DRUM	AGUJA DE SELECTORINA
7	M107	M107	M107	M107	ARBRE DE SELECTEUR CPL	SHIFT SHAFT WITH PAWL ASSY	ÁRBOL SELECTOR
8	M110	M110	M110	M110	RESSORT RAPPEL SELECTION	SPRING SHIFT LEVER	MUELLE RETORNO SELECTOR
9	M111	M111	M111	M111	RESSORT RAPPEL COULISSEAU	PAWL ASSY SPRING	MUELLE RETORNO ESCORPIÓN
10	M113	M113	M113	M113	DOUILLE CENTRAGE RESSORT RAPPEL	SPACER SPRING SHIFT LEVER	CASQUILLO CENTRAJE MUELLE
11	M114	M114	M114	M114	LEVER DE VERROUILLAGE CPL	INDEX LEVER ASSY	PALANCA DE CIERRE SELECTOR
12	M117	M117	M117	M117	RESSORT DE RAPPE LEVIER VERROUIL	INDEX SPRING	MUELLE RETORNO PALANCA DE CIERRE
13	M118	M118	M118	M118	AX DE FOURCHETTE COURT	FORK SPINDLE	EJE DE HORQUILLA CORTO
14	M119	M119	M119	M119	AXE DE FOURCHETTE LONG	FORK SPINDLE LONG	EJE DE HORQUILLA LARGO
15	M121	M121	M121	M121	DOUILLE LEVIER VERROUILLAGE	COLLAR	CASQUILLO PALANCA CIERRE
16	M123	M123	M123	M123	ROULEMENT 25x37x7 R6 1805	R61805 BEARING 25x37x7 R6 1805	COJINETE 25X37X7
17	M124	M124	M124	M124	JOINT A LEVRE G28x37x4	SEAL G28x37x4	RETÉN 28X37X4 OIL
18	M126	M126	M126	M126	JOINT LEVRE 12x19x5 DL	OIL SEAL 12x19x5 DL	RETÉN 12X19X5 DL
19	M127	M127	M127	M127	SELECTEUR EXTERIEUR	SHIFT LEVER ASSY	PALANCA DE CAMBIO
20	M122	M122	M122	M122	PION CLAVETAGE NRA 3X11.8	OIL SEAL 3X11,8	AGUJA DESMO NRA 3X11.8
21	M252	M252	M252	M252	VIS CHC 6x20	SCREW CHC 6x20	TORNILLO M6X20 DIN 912
22	M253	M253	M253	M253	VIS CHC 6x30	SCREW CHC 6x30	TORNILLO M6X30 DIN 912

**Demarreur / Kickstart / Sistema de puesta en marcha**

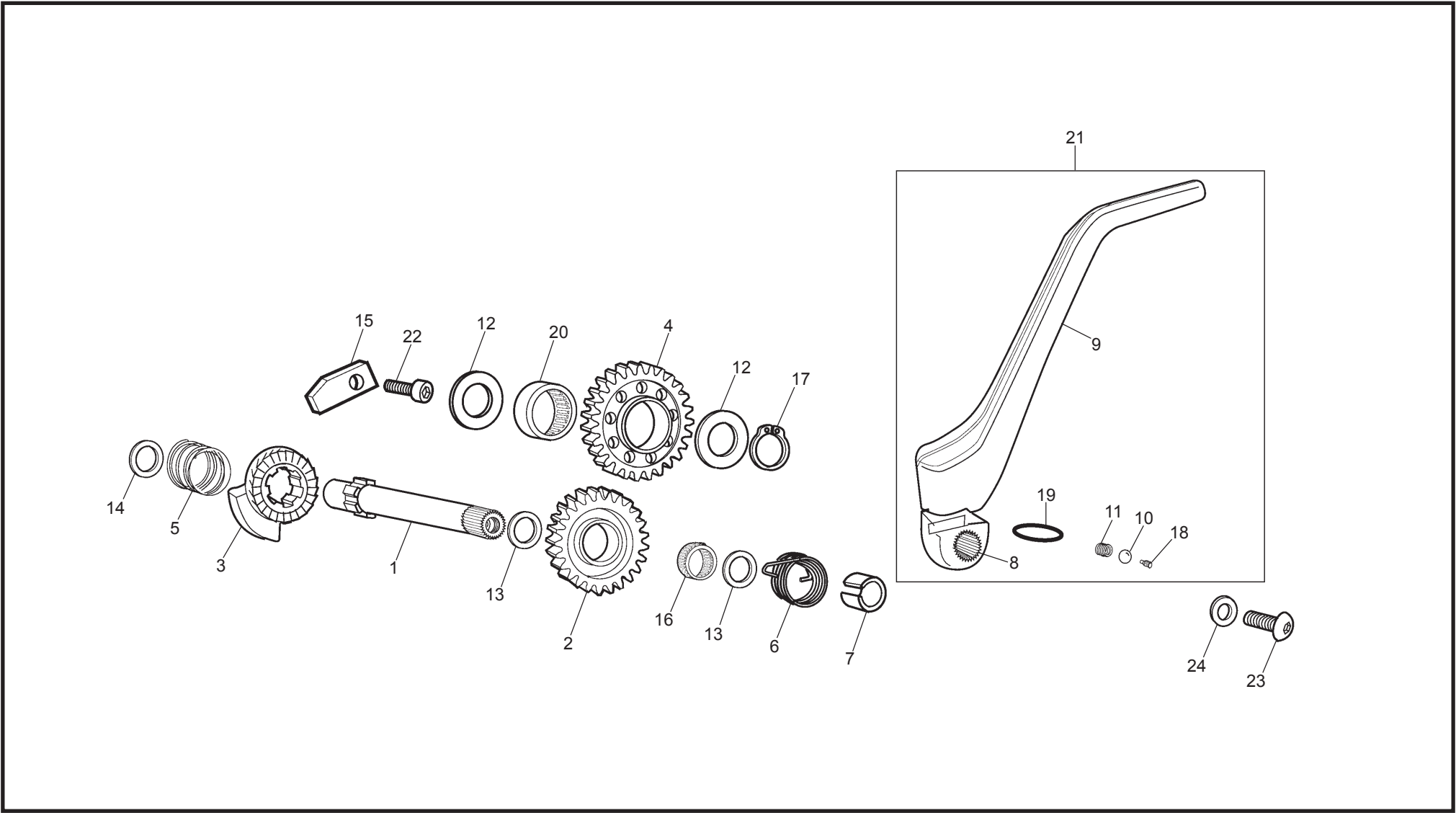

## Demarreur / Kickstart / Sistema de puesta en marcha

POS.	1.2	2.0	2.5	2.9	FRANÇAIS	ENGLISH	ESPAÑOL
1	M150	M150	M150	M150	ARBRE LANCEUR	KICKSTARTER SHAFT	EJE ARRANQUE
2	M151	M151	M151	M151	PIGNON LIBRE DENT DE LOUP	KICKSTARTER PINION	PIÑÓN TRINQUETE
3	M152	M152	M152	M152	COULISSEAU DENT DE LOUP	KICKSTARTER FREE RACHET	TRINQUETE DESPLAZABLE
4	M153	M153	M153	M153	ROUE INTERMEDIAIRE	KICKSTARTER IDLE GEAR	RUEDA INTERMEDIA
5	M155	M155	M155	M155	RESSORT COULISSEAU D DE L	COMPRESSION SPRING	MUELLE TRINQUETE
6	M156	M156	M156	M156	RESSORT DE RAPPEL	KICKSTARTER SPRING	MUELLE DE RETORNO
7	M157	M157	M157	M157	DOUILLE CENTRAGE RESSORT	KICKSTARTER SPRING SPACER	CASQUILLO CENTRAJE MUELLE
8	M158	M158	M158	M158	NOIX DE KICK	KICKSTARTER LOWER CLAMP	MUÑEQUILLA PEDAL ARRANQUE
9	M159	M159	M159	M159	LEVIER DE KICK	KICKSTARTER UPPER LEVER	PEDAL ARRANQUE
10	M160	M160	M160	M160	BILLE 5.5	5.5 BALL	BOLA 5.5
11	M161	M161	M161	M161	RESSORT DE POUSSEE BILLE	BALL SPRING	MUELLE PULSADOR BOLA
12	M163	M163	M163	M163	RONDELLE INA AS 17x30x1	WASHER INA AS 17x30x1	ARANDELA INA AS17X30X1
13	M164	M164	M164	M164	RONDELLE ARBRE 17x25x1	WASHER 17x25x1	ARANDELA EJE ARRANQUE 17X25X1
14	M165	M165	M165	M165	RONDELLE ARBRE 16x25x1	WASHER 16x25x1	ARANDELA EJE ARRANQUE 16X25X1
15	M166	M166	M166	M166	BUTEE COULISSEAU D DE L	KICKSTARTER RACHET STOP	TOPE TRINQUETE DESPLAZABLE
16	M167	M167	M167	M167	CAGE AIGUILLE PIGNON DENT LOUP	NEEDLE BEARING K17x20x10	JAULA AGUJAS PIÑÓN TRINQUETE
17	M171	M171	M171	M171	SEGMENT ARRET DIAN 17	RETAINING RING 17	SEEGER DIÁMETRO 17
18	M169	M169	M169	M169	VIS SANS TETE	SET SCREW	PRISIONERO
19	M168	M168	M168	M168	TORIQUE 14X2	O-RING 14X2	TÓRICA 14X2
20	M077	M077	M077	M077	DOUILLE AIGUILLE HK1712 B	NEEDLE ROLLER BEARING HK1712 B	JAULA AGUJAS HK1712 B
21	M149	M149	M149	M149	KICK COMPLETE	COMPLETE KICKSTARTER LEVER ASSEMBLY	PEDAL COMPLETO
22	M251	M251	M251	M251	VIS CHC 6x16	SCREW CHC 6x16	TORNILLO M6X16 DIN 912
23	M280	M280	M280	M280	VIS BHC 8x16	SCREW BHC 8x16	TORNILLO M8X16 ULS
24	M319	M319	M319	M319	RONDELLE 8x18x1.5	WASHER 8x18x1.5	ARANDELA 8X18X1.5 CÓNICA DIN

**Ensemble / Ignition / Encendido**

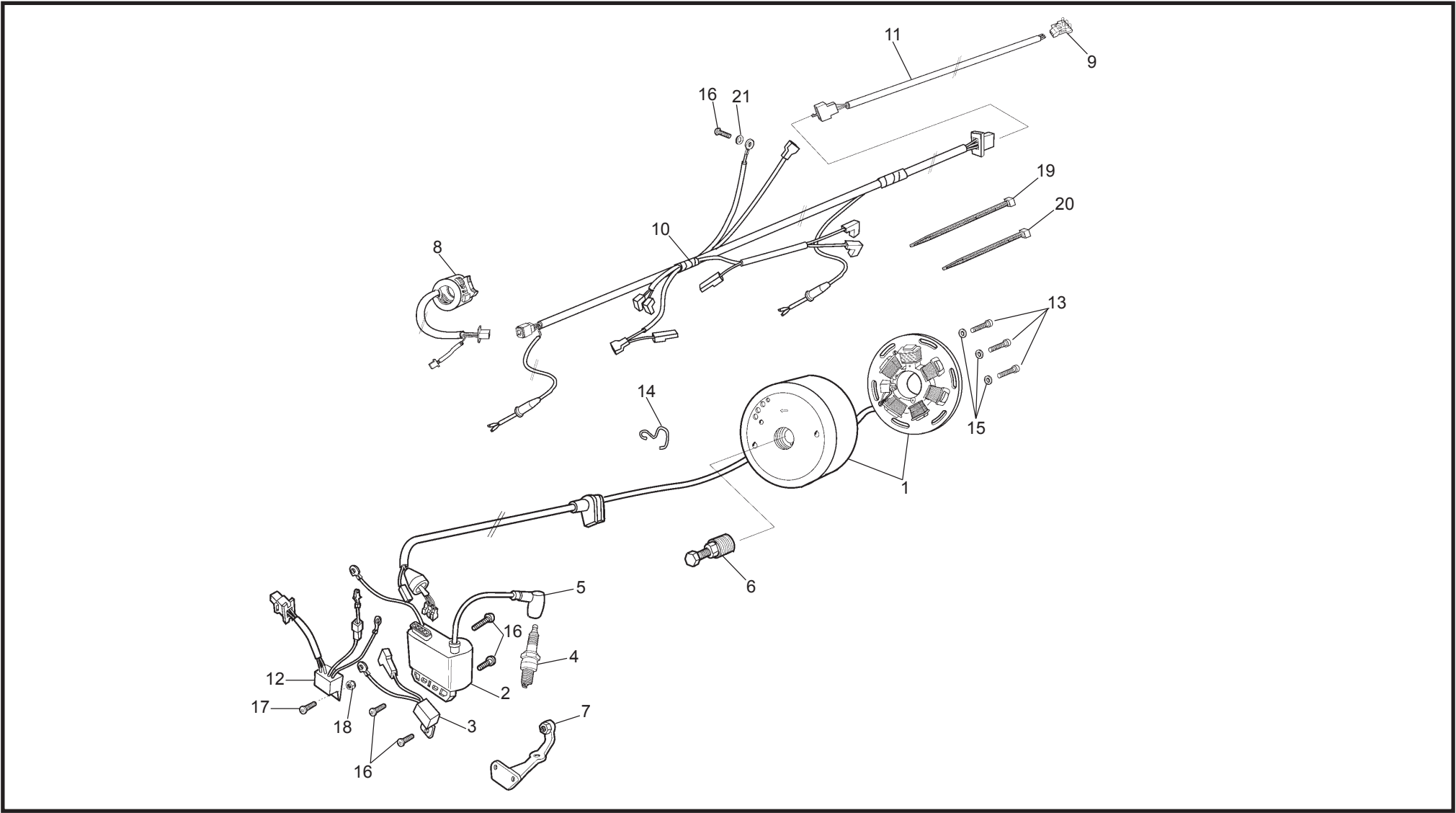

## Ensemble / Ignition / Encendido

POS.	1.2	2.0	2.5	2.9	FRANÇAIS	ENGLISH	ESPAÑOL
1	.....	M180	M180	M180	ALLUMAGE CPL «DUCATI»	IGNITION COMPLETE «DUCATI»	ENCENDIDO COMPLETO «DUCATI»
1	M243	M397	M397	M397	ALLUMAGE CPL «LEONELLI»	IGNITION COMPLETE «LEONELLI»	ENCENDIDO COMPLETO «LEONELLI»
2	M181	M181	M181	M181	BOBINE HT «DUCATI»	COIL «DUCATI»	BOBINA «DUCATI»
2	M398	M398	M398	M398	BOBINE HT «LEONELLI»	COIL «LEONELLI»	BOBINA «LEONELLI»
3	M182	M182	M182	M182	REGULATEUR	REGULATOR	REGULADOR
4	M183	M183	M183	M183	BOUGIE	SPARK PLUG	BUJÍA
5	M184	M184	M184	M184	ANTI PARASITE	SPARK PLUG CAP	PIPA BUJÍA
6	R075	R075	R075	R075	OUTIL EXTRACTEUR ROTOR ALLUMAGE	FLYWHEEL PULLER	EXTRACTOR ENCENDIDO
7	C018	C018	C018	C018	SUPPORT BOBINE	CDI BOX BRACKET	SOPORTE BOBINA
8	C038	C038	C038	C038	COMUTATEUR ELECTRIQUE	LIGHT SWITCH ASSEMBLY	CONMUTADOR LUCES
9	C041	C041	C041	C041	LED ARRIERE	REAR BULB	BOMBILLA TRASERA
10	C037	C037	C037	C037	FAISSEAU ELECTRIQUE	WIRING HARNESS	INSTALACIÓN ELÉCTRICA
11	C044	C044	C044	C044	LOOM FAISSEAU ELECTRIQUE FEU ARRIERE	REAR WIRING HARNESS	INSTALACIÓN ELÉCTRICA TRASERA
12	C039	C039	C039	C039	DIODE REDRESSEUSE	DIODE	RECTIFICADOR
13	M250	M250	M250	M250	VIS CHC 5x16	SCREW CHC 5x16	TORNILLO M5X16 DIN 912
14	M273	M273	M273	M273	CAVALIER NORMA BSL1x8	FORMED WIRE CLIP	BRIDA NORMA BSL1X8
15	M275	M275	M275	M275	RONDELLE x 5	WASHER x5	ARANDELA 5 DIN125 A
16	M282	M282	M282	M282	VIS BHC 6x10	SCREW BHC 6x10	TORNILLO M6X10 ULS
17	M283	M283	M283	M283	VIS BHC 6x16	SCREW BHC 6x16	TORNILLO M6X16 ULS
18	M306	M306	M306	M306	ECROU NYLSTOP M6	NUT NYLSTOP M6	TUERCA NYLSTOP M6
19	M330	M330	M330	M330	COLLIER 178x4.8	ZIP TIE 178 X 4.8	BRIDA 178X4.8
20	M331	M331	M331	M331	COLLIER 100x2.5	ZIP TIE 80 X 2.5	BRIDA 100X2.5
21	M274	M274	M274	M274	RONDELLE GROSVER X6 DIN 67985	WASHER 6 DIN 67985	ARANDELA DENTADA 6 DIN 67985
22	.....	.....	.....	.....	FAISSEAU MINI 80 TRIAL	ENGINE STOP BUTTON 80 TRIAL	INSTALACIÓN REDUCIDA 80 TRIAL
23	.....	.....	.....	.....	BOUTON STOP 80 TRIAL	WIR.HARN. FOR ENGINE STOP BUT.80TRIAL	BOTÓN STOP 80 TRIAL

Transmission primaire / Primary drive / Transmisión primaria

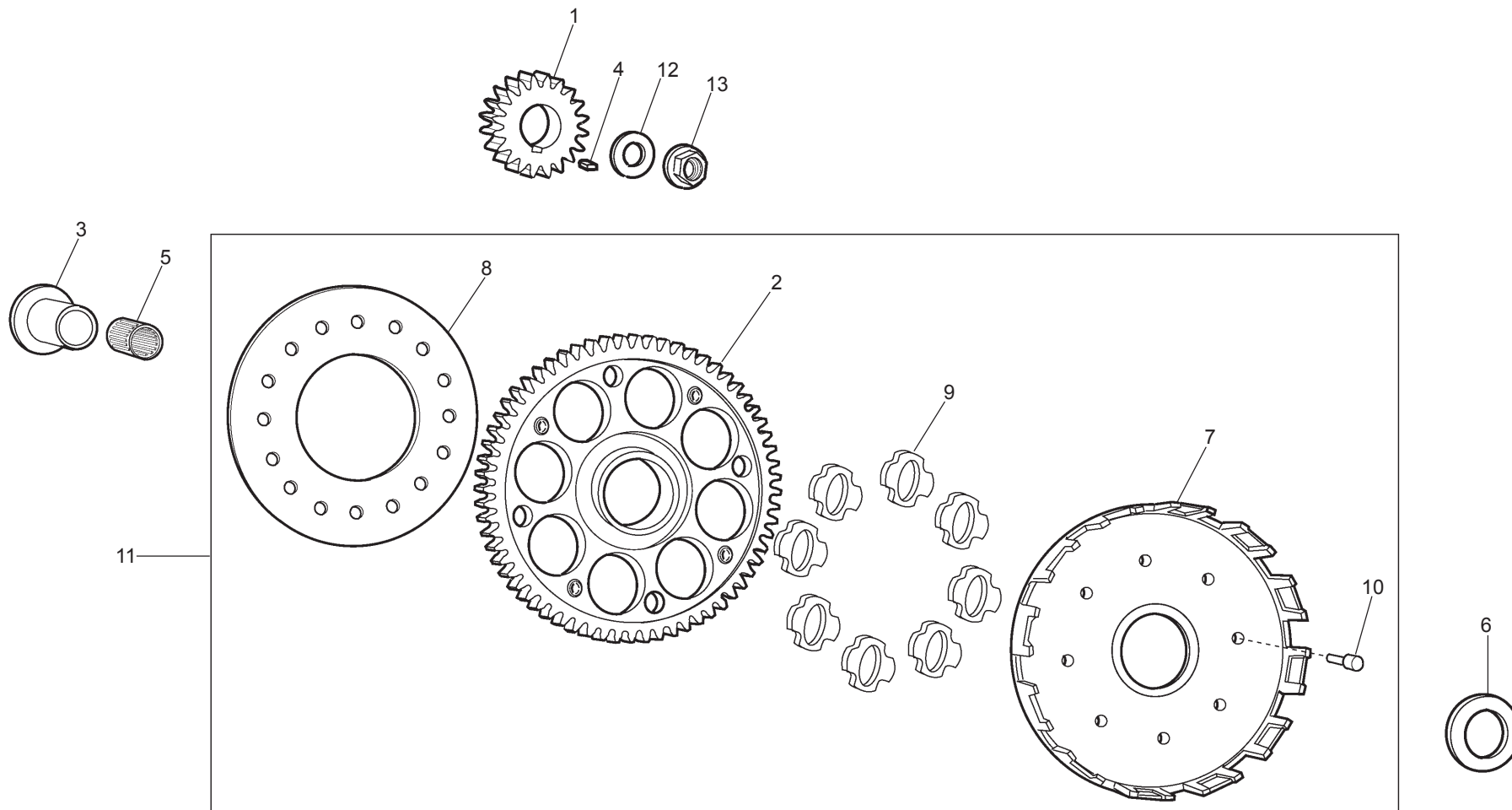

**Transmission primaire / Primary drive / Transmisión primaria**

POS.	1.2	2.0	2.5	2.9	FRANÇAIS	ENGLISH	ESPAÑOL
1	M200	M200	M200	M200	PIGNON PRIMAIRE	PRIMARY DRIVE CRANK PINON	PIÑÓN PRIMARIA
2	M201	M201	M201	M201	ROUE PRIMAIRE	PRIMARY DRIVE CLUTCH PINON	RUEDA PRIMARIA
3	M203	M203	M203	M203	DOUILLE ROUE PRIMAIRE	SPACER PRIMARY DRIVE	CASQUILLO RUEDA PRIMARIA
4	M204	M204	M204	M204	CLAVETTE PIGNON PRIMAIRE	WOODRUFF KEY PRIMARY DRIVE	CHAVETA PIÑÓN PRIMARIA
5	M205	M205	M205	M205	CAGE A AIGUILLE 25x33x24	NEEDLE BEARING 25x33x24	JAULA AGUJAS 25X33X24
6	M208	M208	M208	M208	RONDEILLE BUTEE R PRIM INA AS 2035	PRIMARY WASHER AS 2035	ARANDELA TOPE PRIMARIA INA AS 2035
7	M357	M357	M357	M357	HOLDER CLOCHE	CLUTCH BASKET	CAMPANA EMBRAGUE
8	M359	M359	M359	M359	RONDELLE	SHIM	PLATO REMACHES
9	M358	M358	M358	M358	SILENT BLOCK	SILENT BLOCK	SILENT BLOCK
10	M270	M270	M270	M270	RIVET 4X15	RIVET 4X15	REMACHE 4X15
11	M360	M360	M360	M360	GROUPE CLOCHE	CLUTCH HUB BASKET ASSEMBLY	CONJUNTO CAMPANA
12	M206	M206	M206	M206	RONDELLE BELLEVILLE 14.2X28X1.5	BELLEVILLE SPRING	ARANDELA CÓNICA 14.2X25X1.5
13	M295	M295	M295	M295	ECROU 14x125	HEX NUT M14x125	TUERCA 14X125

**Carburateur / Carburetor / Carburador**

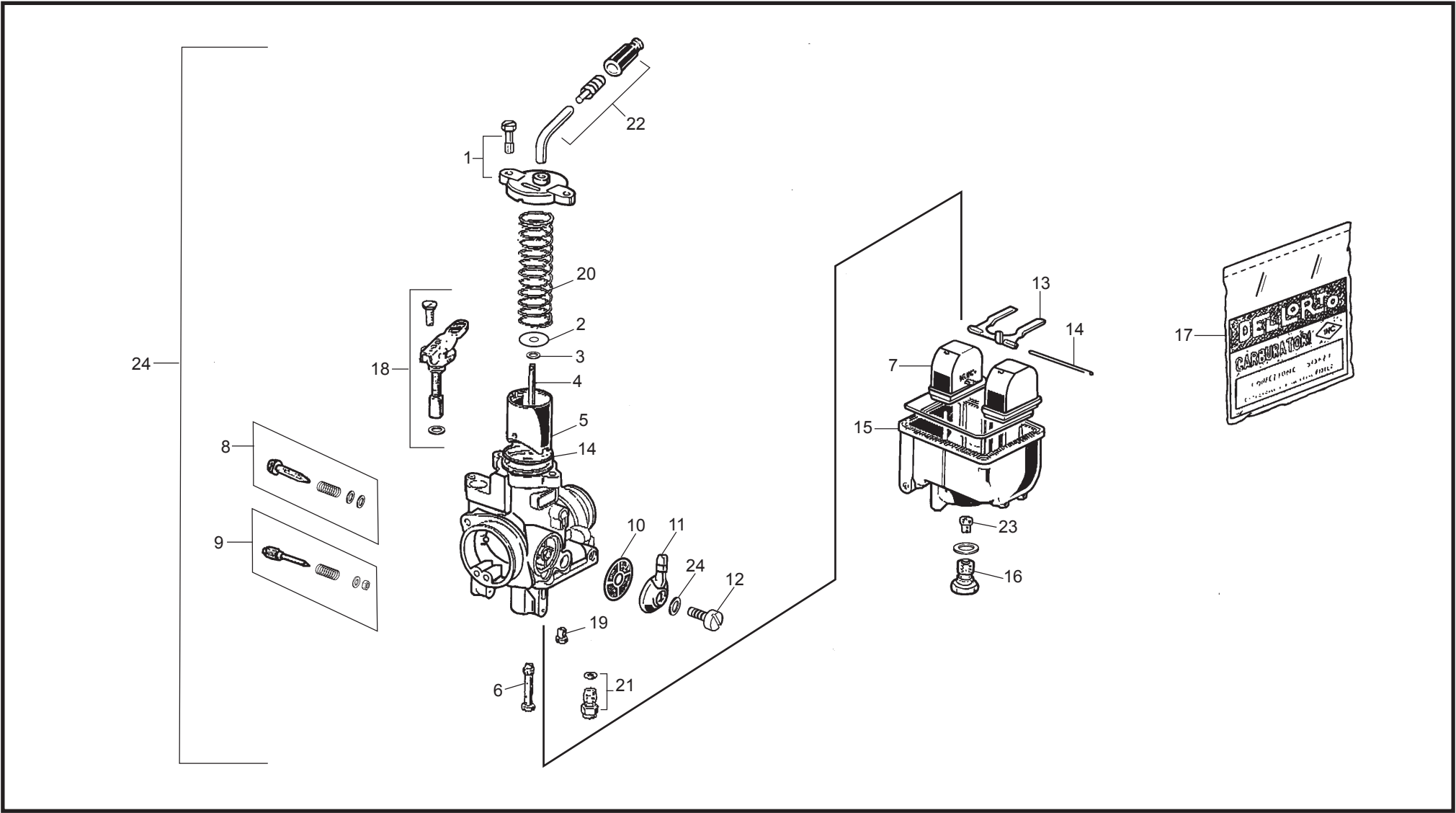

**Carburateur / Carburetor / Carburador**

POS.	1.2	2.0	2.5	2.9	FRANÇAIS	ENGLISH	ESPAÑOL
1	R369	R369	R369	R369	KIT COUVERCLE BOISSEAU	CARBURETOR COVER	TAPA CARBURADOR
2	R370	R370	R370	R370	PLATINE DE RESSORT CARBU	WASHER STOP	ARANDELA TOPE AGUJA
3	R371	R371	R371	R371	CLIP AIGUILLE CARBU	NEEDLE CLIP	CLIP AGUJA
4	R372	R372	R372	R372	AIGUILLE CARBU	NEEDLE	AGUJA
5	R373	R373	R373	R373	BOISSEAU	SLIDE	CAMPANA
6	R374	R374	R374	R374	PULVERISATEUR CARBU	SPRAYER	PULVERIZADOR
7	R375	R375	R375	R375	FLOTEUR DE CARBU	FLOAT	BOYA
8	R376	R376	R376	R376	KIT VIS RGUL GAS CARBU	IDLE SCREW	TORNILLO RELENTÍ
9	R377	R377	R377	R377	KIT VIS RGUL ESSENCE CARBU	FUEL SCREW	TORNILLO AIRE
10	R378	R378	R378	R378	FILTRE ESS CARBU	FUEL FILTER	FILTRO GASOLINA
11	R379	R379	R379	R379	PIPETTE RECCORD TUBE ESS	FUEL FILTER COVER	PIPETA TUBO GASOLINA
12	R380	R380	R380	R380	VIS PIPETTE CARBU	SCREW	TORNILLO PIPETA
13	R381	R381	R381	R381	BALANCIER DE FLOTEUR CARBU	FLOAT BOWL LEVER	BALANCÍN
14	R382	R382	R382	R382	AXE BALANCIER FLOTEUR CARBU	SHAFT	EJE BALANCÍN
15	R383	R383	R383	R383	CUVE CARBURATEUR	FLOAT	CUBA CARBURADOR
16	R384	R384	R384	R384	VIS FIXATION CUVE	SCREW	TORNILLO FIJACIÓN CUBA
17	R385	R385	R385	R385	KIT JOINT CARBURATEUR	GASKET SET	KIT JUNTAS
18	R147	R147	R147	R147	GROUPE STARTER	COLD STARTER ASSEMBLY	LEVA ESTÁRTER
19	R140	R140	R140	R140	GICLEUR RALENTI 30	PILOT JET 30	PULVERIZADOR RALENTÍ 30
19	R142	R142	R142	R142	GICLEUR RALENTI 32	PILOT JET 32	PULVERIZADOR RALENTÍ 32
19	R143	R143	R143	R143	GICLEUR RALENTI 33	PILOT JET 33	PULVERIZADOR RALENTÍ 33
19	R144	R144	R144	R144	GICLEUR RALENTI 34	PILOT JET 34	PULVERIZADOR RALENTÍ 34
19	R145	R145	R145	R145	GICLEUR RALENTI 35	PILOT JET 35	PULVERIZADOR RALENTÍ 35
19	R146	R146	R146	R146	GICLEUR RALENTI 36	PILOT JET 36	PULVERIZADOR RALENTÍ 36

**Carburateur / Carburetor / Carburador**

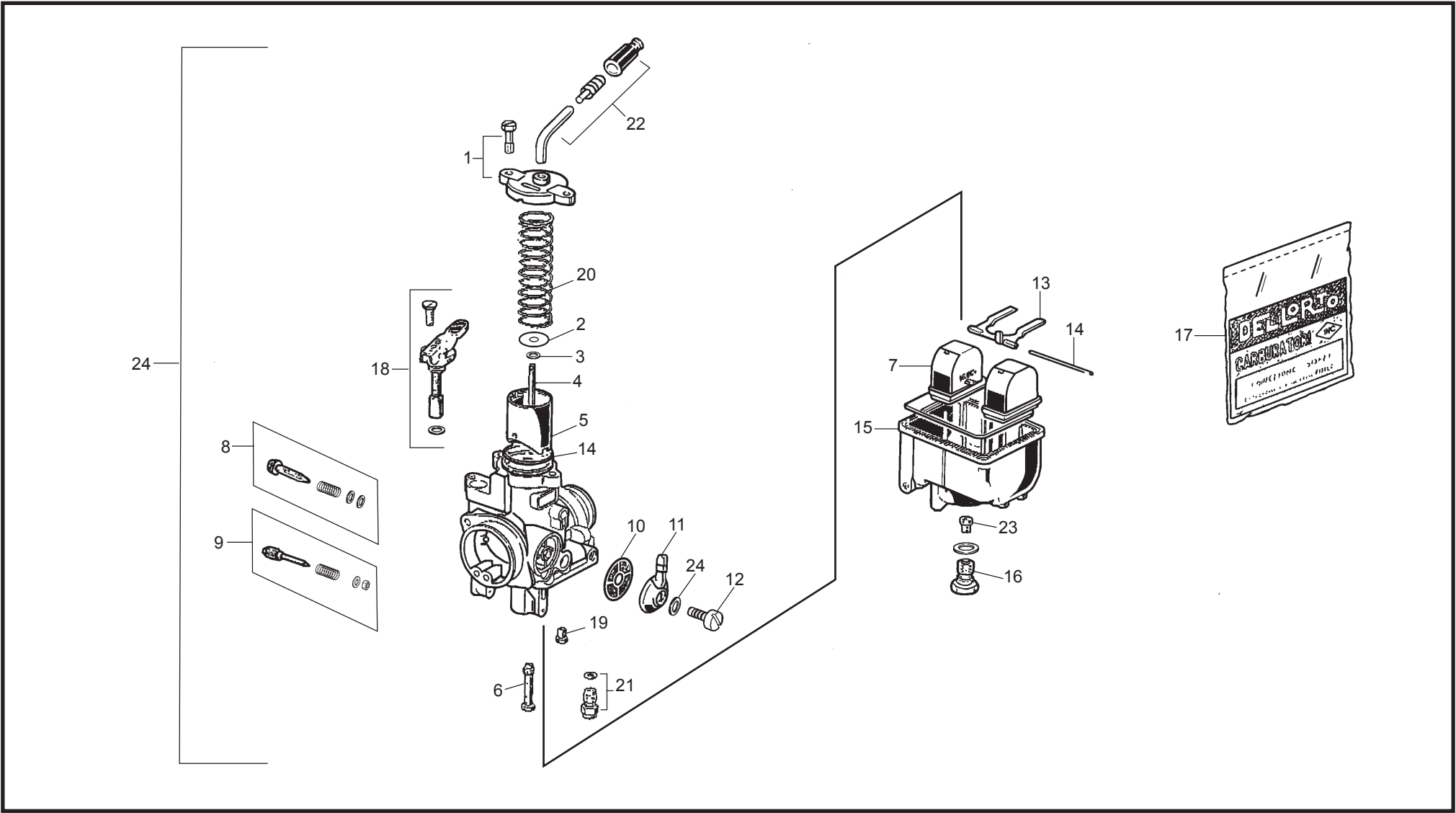

**Carburateur / Carburetor / Carburador**

POS.	1.2	2.0	2.5	2.9	FRANÇAIS	ENGLISH	ESPAÑOL
20	M044	M044	M044	M044	RESSORT CARBURATEUR	SPRING CARBURETOR	MUELLE CARBURADOR
21	R394	R394	R394	R394	VALVE AGUILLE 33	VALVE 33	VÁLVULA AGUJA 33
22	R237	R237	R237	R237	GUIDE CARBURATEUR	CARBURETOR INLET VALVE	CURVA GUÍA CARBURADOR
23	R120	R120	R120	R120	GICLEUR PRINCIPAL 120	MAIN JET 120	PULVERIZADOR PRINCIPAL 120
23	R121	R121	R121	R121	GICLEUR PRINCIPAL 121	MAIN JET 121	PULVERIZADOR PRINCIPAL 121
23	R122	R122	R122	R122	GICLEUR PRINCIPAL 122	MAIN JET 122	PULVERIZADOR PRINCIPAL 122
23	R123	R123	R123	R123	GICLEUR PRINCIPAL 123	MAIN JET 123	PULVERIZADOR PRINCIPAL 123
23	R124	R124	R124	R124	GICLEUR PRINCIPAL 124	PMAIN JET 124	PULVERIZADOR PRINCIPAL 124
23	R125	R125	R125	R125	GICLEUR PRINCIPAL 125	MAIN JET 125	PULVERIZADOR PRINCIPAL 125
23	R126	R126	R126	R126	GICLEUR PRINCIPAL 126	MAIN JET 126	PULVERIZADOR PRINCIPAL 126
23	R127	R127	R127	R127	GICLEUR PRINCIPAL 127	MAIN JET 127	PULVERIZADOR PRINCIPAL 127
23	R128	R128	R128	R128	GICLEUR PRINCIPAL 128	MAIN JET 128	PULVERIZADOR PRINCIPAL 128
23	R129	R129	R129	R129	GICLEUR PRINCIPAL 129	MAIN JET 129	PULVERIZADOR PRINCIPAL 129
23	R130	R130	R130	R130	GICLEUR PRINCIPAL 130	MAIN JET 130	PULVERIZADOR PRINCIPAL 130
24	M020	M020	M020	M020	CARBURATEUR COMPLET	CARBURETOR COMPLETE	CARBURADOR COMPLETO

# **SHERCO**

*Motorcycles*

**Junior**  
**World**  
**Champion**  
**2001**

with  
Josep Manzano



[www.sherco-moto.com](http://www.sherco-moto.com)

**SHERCO** s.A.R.L. <[information@sherco-moto.com](mailto:information@sherco-moto.com)> Fax : +34 93 865 56 91